

**HONDA**

**2012** | NORTH AMERICAN  
ENVIRONMENTAL REPORT



BLUE SKIES FOR  
OUR CHILDREN

---

## Table of Contents

---

This report covers Honda’s activities in the United States, Canada, and Mexico — including company policies, the overall direction of Honda’s environmental initiatives, and a current assessment of the environmental impact of its operations — for the fiscal year that began April 1, 2011, and ended March 31, 2012 (FY12).

---

---

---

---

---

---

---

---

---

---

---

---

---

---

---

---

---

---

---

---

---

---

---

---

---

---

---

---

---

---

### To navigate this report

Click on the links at the right of each page to jump to sections within the report, or use the page forward/back arrows.

Click on any item in the table of contents above to go to that page.

Use the left and right arrow keys on your keyboard to move between pages.

In full-screen mode (accessible from the “View” tab on the Adobe toolbar), left-click to move to the next page, right-click to move to the previous page.

### Electronic format

To reduce the environmental impact of Honda’s reporting, this report is published in electronic format only. Please consider the environment before printing.

### We value your opinion

We are interested in your response to this report, which will help us improve future reporting. Please [click here](#) to complete a brief survey.



BLUE SKIES FOR  
OUR CHILDREN

“Blue Skies for Our Children” is the global environmental slogan adopted by Honda to express its commitment to the realization of its environmental vision through expanded environmental initiatives. Honda engineers, who took on the challenge to meet the stringent new emissions standards of the 1970s U.S. Clean Air Act, used the phrase “blue skies for our children” as a passionate rallying cry to devote themselves to this effort. This slogan continues to represent Honda’s passion toward its environmental commitment, which has not wavered and will remain resolute in the future.







## 2012 Executive Summary



**Product Development** — Improving the fuel efficiency of Honda products is the single most important part of our environmental effort. Honda's "design for the environment" initiatives also extend to the creation of products that use fewer scarce, non-recyclable, or potentially harmful materials and that offer greater ease of dismantling for improved recyclability.

CATEGORY	PRODUCT	FY12 RESULTS
Recyclability	Autos	<ul style="list-style-type: none"> <li>Maintained a 90% level of design recyclability.</li> </ul>
	Powersports and Power Equipment	<ul style="list-style-type: none"> <li>Maintained a 95% level of design recyclability.</li> </ul>
Substances of Concerns (SOCs)	Autos	<ul style="list-style-type: none"> <li>Continued efforts to eliminate PVC from automobile interiors.</li> <li>Continued phasing in the use of mercury-free display monitors.</li> </ul>
	Powersports	<ul style="list-style-type: none"> <li>Introduced low-lead ATV wheel hubs.</li> </ul>
Fuel Economy/CO <sub>2</sub> Emissions	Autos	<ul style="list-style-type: none"> <li>Introduced a new Honda CR-V with a 2 mpg increase in its U.S. EPA combined fuel economy rating compared to the previous model.</li> <li>Began leasing the Fit EV battery electric vehicle — with an industry-leading EPA fuel economy rating of 118 MPGe — to customers in select U.S. markets.</li> <li>Announced new 'Earth Dreams Technology' powertrains — designed to deliver significantly increased fuel efficiency along with enhanced performance — including a direct-injected 4-cylinder gasoline engine mated to a new continuously variable transmission (CVT), and a new two-motor hybrid system, both being applied to the redesigned Accord, Honda's best-selling model in North America.</li> </ul>
	Powersports	<ul style="list-style-type: none"> <li>Launched NC700X motorcycle with up to 40% higher fuel economy than competing products.</li> </ul>
	Power Equipment	<ul style="list-style-type: none"> <li>Introduced two hybrid snow blowers powered by new GX engines with 9-19% improvement in fuel economy versus previous engines.</li> <li>Introduced quieter and more fuel-efficient EB10000 Industrial Series generator with variable ignition timing.</li> </ul>



**Purchasing** — Honda is working with more than 600 companies that supply parts and materials to Honda plants in North America to develop improved methods of tracking and reporting on emissions and other environmental impacts within its North American parts supply chain ("Green Purchasing"), as well as implementing measures to reduce the impact of shipping parts from suppliers to Honda factories in the region ("Green Logistics").

CATEGORY	PRODUCT	FY12 RESULTS
"Green Purchasing"	All Products	<ul style="list-style-type: none"> <li>Continued efforts to promote better tracking and reporting of greenhouse gas emissions in Honda's North American supply chain.</li> </ul>
"Green Logistics"	All Products	<ul style="list-style-type: none"> <li>Continued efforts to reduce CO<sub>2</sub> emissions and other environmental impacts from the shipment of parts and materials: more than 6 million pounds of CO<sub>2</sub> emissions avoided in FY12.</li> </ul>



**Manufacturing** — Honda operates 14 plants in North America, including seven that together produce more than 85% of the Honda and Acura automobiles sold in the region. Honda’s ongoing effort to reduce the environmental impact of its manufacturing operations is strongly focused on reducing CO<sub>2</sub> emissions through improved energy efficiency and reducing waste through expanded recycling activity. Other efforts include minimizing waster use and emissions of potentially volatile compounds.

CATEGORY	PRODUCT	FY12 RESULTS
CO <sub>2</sub> Emissions	All Products	<ul style="list-style-type: none"> <li>CO<sub>2</sub> emissions intensity of production activity was reduced 10% while energy use was down 4% versus the previous year*</li> </ul>
Waste	Autos	<ul style="list-style-type: none"> <li>Solid waste per automobile rose 2.6% to 181 kg/auto*</li> <li>Waste to landfill per automobile produced was reduced 48% from the previous year (FY11) and 96.8% from the baseline year (FY01).</li> <li>10 of 14 Honda plants in North America operated with zero waste to landfill.</li> </ul>
Water		<ul style="list-style-type: none"> <li>Water use per automobile produced rose 3.7% from the previous year*</li> </ul>
VOC Emissions		<ul style="list-style-type: none"> <li>VOC emissions from auto body painting were reduced 3.9% from the previous fiscal year (FY11) and 50% from the baseline year (FY01).</li> </ul>

\* Reduced production levels in North America in FY12, as a result of part supply shortages arising from the March 11, 2011, Japan earthquake, severely impacted the emissions, water and waste intensity (per-unit measure) of production operations in the region.



**Sales and Service** — To meet the service needs of its customers, Honda delivers millions of parts each year from suppliers to retail dealers in the region. The company is working to reduce both waste and emissions associated with the packaging and transportation of service parts. In FY12, the company also initiated a program to extend these environmental efforts to its U.S. automobile dealers.

CATEGORY	PRODUCT	FY12 RESULTS
CO <sub>2</sub> Emissions	All Products	<ul style="list-style-type: none"> <li>CO<sub>2</sub> emission from the transportation of service parts in the U.S. was reduced 23.8% since FY08, when Honda began tracking this data.</li> <li>Through various initiatives, including modal shifts, increased parts packing efficiency, and application of Route Tracker technology, 5,076 metric tons of CO<sub>2</sub> were avoided in FY12.</li> </ul>
Waste	Autos	<ul style="list-style-type: none"> <li>Honda has established a goal to eliminate waste to landfill from its parts packaging, and distribution operation in the U.S.</li> <li>In FY12, a pilot program at one of nine U.S. parts distribution centers resulted in zero waste to landfill for the facility in FY12.</li> <li>Ongoing efforts to reduce, reuse and recycle waste material resulted in 11,588 pounds of waste, comprising 92% of all waste material from parts warehouse operations, being diverted from landfills in FY12.</li> </ul>
“Green Dealers”		<ul style="list-style-type: none"> <li>American Honda launched its first-ever “green dealer” award program with Honda and Acura automobile dealers in the U.S., including a requirement for qualifying dealers to reduce their dealership’s energy use by 10%.</li> </ul>



**In-Use** — Generally, the largest environmental impacts of Honda products come from the customer's use of the products, primarily greenhouse gas and smog-forming exhaust emissions resulting from the combustion of fossil fuels. In the case of automobiles, roughly 86% of life-cycle CO<sub>2</sub> emissions occur during customer use.

CATEGORY	PRODUCT	FY12 RESULTS
CO <sub>2</sub> Emissions	Autos	<ul style="list-style-type: none"> <li>The adjusted composite CO<sub>2</sub> emissions of the company's MY11 U.S. automobile fleet, at 345 grams/mile, was reduced 9.4% versus MY07 results, and was 11.8% lower (better) than the U.S. auto industry average for MY11.</li> <li>The CO<sub>2</sub>-adjusted fuel economy of the company's MY11 U.S. vehicle fleet, at 25.7 mpg, was increased 7.5% versus MY07 results, and was 12.7% higher (better) than the U.S. auto industry average for MY11.</li> </ul>
	Powersports	<ul style="list-style-type: none"> <li>The fleet average fuel economy of Honda motorcycles sold in North America has been improved 15% versus FY00 results.</li> </ul>



**End of Life** — while Honda does not directly participate in the disposal of its products, the company is working to make its products easier to recycle, while also taking a direct role in reducing waste from the disposal of service parts.

CATEGORY	PRODUCT	FY12 RESULTS
Waste	E-waste, overstock and remanufactured parts	<ul style="list-style-type: none"> <li>34.9 million pounds of e-waste, warranty parts, and overstock parts were diverted from landfills in FY12.</li> <li>Honda continued to increase its remanufactured parts offerings, adding 35 new part numbers in CY12.</li> </ul>



**Administration** — Honda's effort to reduce the environmental impact of its administrative operations is focused on improving the energy efficiency of its facilities and reducing waste material through enhanced recycling efforts.

CATEGORY	PRODUCT	FY12 RESULTS
"Green Building"	North American Facilities	<ul style="list-style-type: none"> <li>In FY12 the company received LEED certification for its twelfth facility in North America, the most of any automaker operating in the region.</li> <li>American Honda completed its largest commercial solar-cell demonstration project — a 100-kilowatt, 800-cell array — at the Santa Clarita, California headquarters of Honda's U.S. motorsports engineering subsidiary, Honda Performance Development.</li> </ul>

---

## Environmental Management

---

Honda has been developing technologies and implementing measures to help overcome environmental challenges since the 1960s. In 1992, the company

issued the Honda Environment Statement to clearly define its approach to environmental issues, which is central to everything we do.

---

### Honda Environmental Statement

“As a responsible member of society whose task lies in the preservation of the global environment, the company will make every effort to contribute to human health and the preservation of the global environment in each phase of its corporate activity. Only in this way will we be able to promote a successful future not only for our company, but for the entire world.”

---

We should pursue our daily business interests under the following principles:

**1** We will strive to recycle materials and conserve resources and energy at every stage of our products' life cycle — from research, design, production, and sales, to service and disposal.

**2** We will strive to minimize and find appropriate methods to dispose of waste and contaminants that are produced through the use of our products, and in every stage of the life cycle of these products.

**3** As both a member of the company and of society, each associate will focus on the importance of making efforts to preserve human health and the global environment, and will do his or her part to ensure that the company as a whole acts responsibly.

**4** We will consider the influence that our corporate activities have on the regional environment and society, and endeavor to improve the social standing of the company.

## Environmental Management

Honda has developed an institutional framework to put into practice the principles of environmental conservation as defined in the Honda Environmental Statement.

Honda's regional operations, including the North America region, are given broad authority to fulfill their operational business responsibilities, which include planning and acting in accordance with Honda's environmental vision to minimize the environmental impact of their local business activities.

A hallmark of Honda environmental initiatives is that planning and execution are not delegated to specialists; rather, they are taken up directly by associates in all departments, who are engaged with environmental issues as part of their duties.

### World Environmental Committee

The World Environmental Committee, established in March 1995, determines annual plans for implementing conservation activities on a global level based on the company's medium-term business plans determined by the Executive Council. The company's president and CEO currently chairs the committee.



### North American Environmental Committee

Regional environmental committees, including the North American Environmental Committee, discuss and evaluate annual achievements under the plan and then, based on the results, create new targets and plans.

PRODUCTS	LOGISTICS	MANUFACTURING	OFFICE AREA	CORPORATE COMMUNICATION
Automobiles Powersports Power Equipment	Product and service parts packaging and distribution	Production Purchasing OEM Parts logistics	"Green Building" Recycling Energy efficiency	Environmental reporting

## Key Practices

### Environmental Risk Management

Honda considers risk management to be an integral part of environmental management. Honda's approach to risk management is reflected in various activities:

- systems for preventing spills and unplanned releases;
- systems for reducing environmental releases; and
- systems for recycling products, components, and manufacturing byproducts, in order to minimize landfill waste.

From long-term planning to daily operations, Honda strives to understand the risks of environmental impact and to make prudent decisions to minimize impacts wherever possible. Honda North America, Inc., a subsidiary of Honda Motor Co., Ltd., serves as auditor, helping to ensure that Honda's various subsidiary companies and its affiliated suppliers in the North America region are in compliance with all applicable environmental laws and regulations. It also provides support to those companies in determining and implementing best practices for Honda's environmental management activities in the region.

### Environmental Laws and Regulations

Regulatory compliance is fundamental to the production and in-use performance of Honda products, and to the continuance of Honda's operations in North America. All Honda companies have systems in place to ensure that their activities comply with all applicable legal requirements.

### Emissions-Related Product Recalls

Honda's policy on product recalls, including emissions-related recalls, is in accordance with the procedures of its Quality Committee, which is composed of senior executives from various divisions of Honda. The Quality Committee makes decisions about Honda products manufactured and sold throughout the world, relying upon recommendations from Honda experts in each region.

### North American Environmental-Related Fines

During the fiscal year ended March 31, 2012, Honda was not party to, or the subject of, any environmental-related administrative or judicial proceedings that the company is required to report<sup>1</sup> to the Securities and Exchange Commission.

## Corrective Actions in FY12

During the fiscal year ended March 31, 2012, Honda initiated five corrective actions in the United States: three Product Update Plans (PUD) and two Voluntary Emission Recalls (VER).

DATE	DETAILS	MODEL(S)	UNITS
2/21/12	<b>U.S. VER:</b> Some ORVR Vent Shut Float Valves may have been incorrectly manufactured, which may allow liquid fuel to enter the vent line leading to the evaporative canister upon refueling.	2012 Pilot, MDX	8,709
8/16/11	<b>U.S. PUD:</b> Under certain driving conditions, inappropriate calibration of the PCM causes catalyst heat damage. The MIL illuminates.	2007 MDX	53,520
8/4/11	<b>U.S. PUD:</b> Due to inappropriate calibration of the PCM, under certain driving conditions, soot may intermittently deposit to oil ring which results in excessive consumption of the engine oil.	08-10 Accord, 2011 Accord AT, 2010 CR-V, 09-10 TSX	1,248,873
8/3/11	<b>U.S. PUD:</b> The OBD system may falsely detect NOx Adsorptive Catalyst deterioration. The MIL illuminates. The cause of the failure is inappropriate programming of the OBD system. For Civic Hybrid, the secondary oxygen sensor may deteriorate, resulting in the MIL illuminating.	03-05 Civic Hybrid	60,931
5/31/11	<b>U.S. VER:</b> Some O-rings that seal a connection in the fuel feed line may have been misaligned which may lead to a small fuel leak.	2012 Civic	1,156

<sup>1</sup> Pursuant to 17 CFR section 229.103

## Honda Assessment of Environmental Issues from a Global Perspective

To realize the Honda Environmental Vision, the company is addressing environmental issues in a comprehensive manner through management policies implemented in each region of the globe. Environmental issues have been organized according to importance, and those that pose the greatest risk to the company's business and stakeholders have been identified (see figure at right). As a global corporation supplying mobility products, Honda sees climate change and energy use, major issues on a global scale, as the greatest challenges facing society. Honda has set forth its own reduction targets for emissions of CO<sub>2</sub> — by far the most significant of all greenhouse gases (GHGs) — and is stepping up efforts to meet these targets in every region and domain (see page 12).

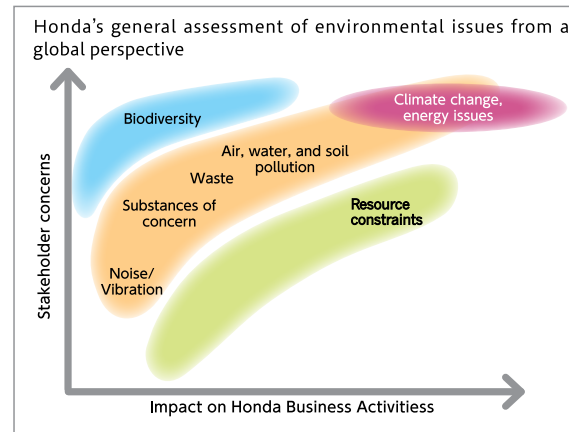

## Global Assessment of Opportunities and Risks of Climate Change

Honda has compiled all of the major opportunities and risks the company currently expects to see from climate change and energy issues (see figure at right) and has been taking the following measures in response:

- To minimize the regulatory risk Honda products face as emitters of GHGs, the company has set — and subsequently achieved — fiscal 2011 CO<sub>2</sub> emissions reduction targets for over 90% of our motorcycle, automobile, and power products.
- Looking forward to 2020, Honda has set new targets to reduce product CO<sub>2</sub> emissions and is actively taking other measures to reduce emissions.

Honda clarified its understanding of risks and opportunities such as these from the perspective of product categories (powersports products, automobiles, and power equipment), with a focus on its business and production development operations, and by region, which is based on a unique regional management structure. Honda's World Environmental Committee assesses these risks and opportunities from a global perspective, the findings of which are used by regional operations (regional environmental committees), business operations, and functional operations in the formulation of management policies and strategies.

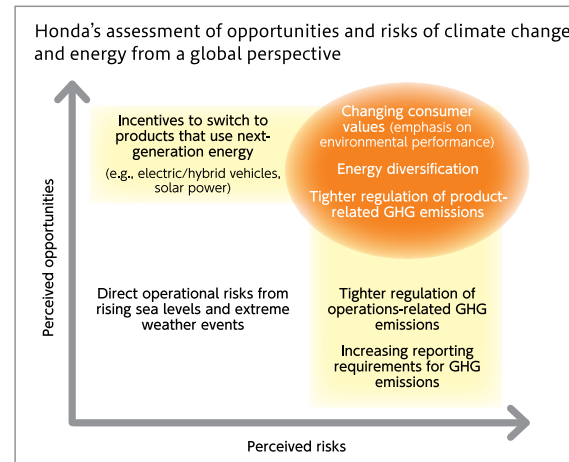

## Addressing Global Climate Change and Energy Use

### 2020 Product CO<sub>2</sub> Emissions Reduction Targets

Reducing CO<sub>2</sub> emissions from our products is a necessary step in combating climate change and energy use issues, which is why Honda established voluntary targets for the reduction of CO<sub>2</sub> emissions from

its products by 2020. The company is aiming for a 30% reduction in fleet average emissions of its automobiles, motorcycles, and power equipment products, compared with FY01 levels.

**2020 Product CO<sub>2</sub> Emissions Reduction Targets**

Global average CO<sub>2</sub> emitted by Honda products

30% reduction (g/km CO<sub>2</sub>)



**Automobiles**  
30% reduction (g/km CO<sub>2</sub>) from 2000 levels by 2020

30% reduction (g/km CO<sub>2</sub>)



**Motorcycles**  
30% reduction (g/km CO<sub>2</sub>) from 2000 levels by 2020

30% reduction (kg/hr CO<sub>2</sub>)



**Power Equipment**  
30% reduction (kg/hr CO<sub>2</sub>) from 2000 levels by 2020

**Regions covered:**  
 Automobiles: Japan, North America, Europe, Asia and Oceania, China, Latin America (more than 90% of global sales)  
 Motorcycles: Japan, North America, Europe, Thailand, India, China, Indonesia, Vietnam, Brazil, Philippines, Malaysia, Pakistan (more than 90% of global sales)  
 Power Equipment: All products sold in all regions

## Progress Toward 2020 CO<sub>2</sub> Emissions Reduction Targets

Honda made no progress toward its target for automobiles in FY12, as it experienced an increase in sales of sport-utility vehicles in North America, which makes up a large share of Honda's global sales, in part due to a reduction in the production of smaller, more fuel-efficient passenger cars as a result of the Great Eastern Japan earthquake and flooding in Thailand. At the same time, emissions from motorcycle and power equipment products were reduced as a result of increased sales of mid-size and handheld engines, which produce relatively fewer emissions per unit, and the launch of more fuel-efficient products such as hybrid snowblowers, electric lawnmowers, and outboard engines.

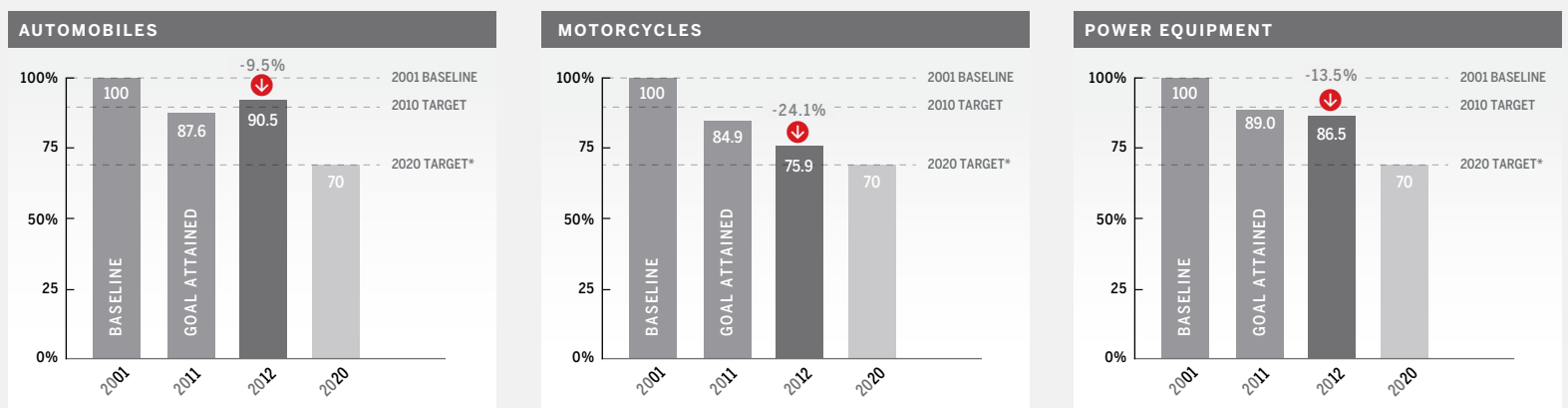

\* 30% reduction from 2001 levels

## Honda's Approach to Climate Change Policy

Honda's "portfolio approach," as depicted on the preceding pages, pursues multiple technology pathways and seeks to address comprehensively the challenges associated with the deployment of new energy and vehicle technologies. At the same time, we recognize that a successful GHG program requires consumer acceptance of the vehicles and alternative fuels developed to reduce GHG

emissions. Solving an environmental challenge as complex as global climate change requires the concerted efforts of industry, government, and consumers.

Using this philosophy as a foundation, Honda takes the following positions on current climate change-related policy issues:

### Honda's Approach to Climate Change Policy in North America

PUBLIC POLICY INITIATIVES	HONDA'S POSITION
<b>Federal Fuel Economy (CAFE) Standards — Greenhouse Gas (GHG) Emissions Standards</b>	Honda believes mandates on vehicle and product performance should be adopted at the federal level as a single national standard, as opposed to a state-by-state approach, as exhibited by the adoption of the White House initiatives for harmonized national fuel economy/GHG emissions standards for vehicle model years 2012–2016 and model years 2017–2025. In today's marketplace, vehicles and other gasoline-powered products, such as lawn-care products, are designed, built, and distributed to meet the needs of an entire country, and sold nationwide. Efforts to regulate GHG emissions the state or province level will inevitably result in inefficiencies, customer dissatisfaction, and increased costs to consumers.
<b>Incentives</b>	Incentives implemented by government entities can be constructive in stimulating nascent and expensive technologies, such as those used in fuel cell-electric vehicles, natural gas vehicles, battery-electric vehicles, and plug-in hybrid electric vehicles. Incentives should be technology-neutral, performance-based, and limited in duration. Both financial incentives, such as consumer tax credits, and non-financial incentives, such as HOV lane access for advanced technology vehicles, can help stimulate demand and enlarge the market for those types of automobiles. At the same time, the non-financial HOV incentive should be balanced with the overall purpose of the carpool lanes, which is traffic congestion mitigation and air quality improvement.
<b>Registries</b>	Any regulatory approach that is calibrated to baseline emissions requires registries that accurately reflect the current situation. Registries should be nationwide to ensure consistent and reliable reporting. Honda supports the U.S. EPA mandatory greenhouse gas reporting rule.
<b>Cap-and-Trade</b>	Cap-and-trade is one potential means of regulating GHG emissions from stationary sources; however, cap-and-trade can penalize companies that are growing market share while providing an unearned windfall to companies that are losing market share. On the mobile sources side, GHG regulations already address CO <sub>2</sub> emissions, thus cap-and-trade is unnecessary.
<b>Biofuels</b> Renewable Fuels Ethanol and Flex Fuel Vehicles	Renewable fuels offer promising opportunities to displace petroleum and could reduce GHG emissions. However, some renewable fuels are more effective at achieving this objective and more sustainable and economically viable than others. Compatibility with existing and future products, a viable distribution network, and a refueling infrastructure are all critical considerations. EPA's approval of a waiver allowing the sale of E15 was premature and does not meet these criteria. Specifically, given that higher ethanol blends are not inherently compatible with legacy products, government must assure that legacy fuels remain in the marketplace, and introduce strong safeguards to prevent misfueling by consumers. Ethanol does offer the promise of higher octane levels which, along with the octane added at the refinery, is important to meet the fueling needs of advanced internal combustion engines. Drop-in fuels, fuels that can be used without major changes to the fueling infrastructure, such as bio-butanol are promising alternatives to ethanol.

## Risks and Opportunities of Climate Change and Energy Use

Based on Honda's global assessment of environmental risks, our North American management team is constantly surveying future environmental, economic, and social trends in the North American region in an effort to anticipate the effect of these trends on our business. Virtually every future risk carries with it an opportunity.

Anticipating and responding quickly to risks gives Honda the greatest degree of flexibility and ensures the sustainability of its business. We are focusing here on three key risk areas: Air Quality, Climate Change, and Energy Security.

KEY AREAS OF RISK MANAGEMENT	RISKS AND OPPORTUNITIES
<p><b>Air Quality</b></p> <p>There are three primary elements to air quality impacts that Honda monitors: pre-cursors to smog (localized health effects), particulate matter (localized health effects and contributor to climate change), and carbon monoxide (local health effects only). Every combustion engine product Honda makes is regulated with respect to one or more of these impacts.</p>	<ul style="list-style-type: none"> <li>• Generally speaking, Honda has aggressively met emissions standards in the region and has worked cooperatively with regulatory agencies to continuously reduce harmful emissions.</li> <li>• While dramatic improvements have been made over the last thirty years, and new priorities (such as climate change) have emerged, air quality goals are continually improving.</li> <li>• Honda does not anticipate that future emissions standards through 2025 pose any significant threat to its business, nor do they represent a significant competitive advantage for Honda.</li> </ul>
<p><b>Climate Change and Energy Scarcity</b></p> <p>The growing demand from society for cleaner, more fuel-efficient products and alternative sources of energy, along with stringent new fuel-economy and greenhouse gas emissions requirements in the U.S. and Canada, pose a significant challenge to the auto industry to accelerate the development and deployment of new technologies while meeting customers' expectations for vehicle performance, utility, safety and affordability.</p>	<ul style="list-style-type: none"> <li>• Honda is strongly focused on the issues of climate change (greenhouse gas emissions) and energy scarcity in all of its business activities, in particular in the development of more fuel-efficient products.</li> <li>• Honda took an active role in helping develop new U.S. fuel economy and greenhouse gas regulations for the period 2017–2025. While these new regulations pose a substantial challenge with respect to the introduction and marketing of new and potentially costly technologies, we embrace the challenge of meeting these new standards through the leveraging of our strong capabilities in the areas of fuel-efficient propulsion systems, reduced running resistance (aerodynamics, low-friction engines, and light weighting), and alternative-energy technology.</li> </ul>

## Improving Fuel Efficiency and Reducing Greenhouse Gas Emissions

Honda is pursuing a “portfolio approach” to addressing both greenhouse gas emissions and energy issues, a strategy that encompasses multiple technology pathways and seeks to comprehensively address the challenges associated with the deployment of new energy and vehicle technologies. Honda’s goal is the advancement of each technology path toward real-world deployments and the accumulation of experience that will help to improve both the technology and market conditions necessary to realize broad-based demand for more fuel-efficient and alternative fuel technologies.

The chart that follows seeks to provide Honda’s perspective in the North American market with respect to this portfolio approach, and to present a clear, concise rating system for various technologies with respect to their potential benefits to society — in the areas of air quality, GHG reduction, and energy security (reduced petroleum consumption) — and the unique challenges to the marketability

of each technology. Without this “scorecard” it can be easy to think that a single technology holds the most promise; however, every new technology involves risks and uncertainties. Technology uncertainties, social benefits, and marketability judgments altogether strengthen Honda’s resolve to proceed along a portfolio approach.

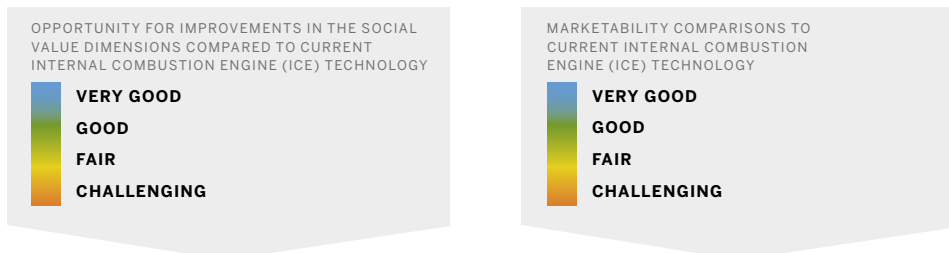

**Many of these judgments are difficult, and may shift over time as information becomes clearer, technologies evolve, or circumstances change. For now, these color-coded references serve as a quick comparison between the current promise of these technologies and strategies for the North American market.**

	Social Values			Marketability				Honda’s effort
	AIR QUALITY	GHG REDUCTION	ENERGY SECURITY	INFRA-STRUCTURE	COST	FULL FUNCTION	APPEAL	
<b>Improved Gasoline Internal Combustion Engine (ICE)</b>	VERY GOOD	FAIR	FAIR	VERY GOOD	VERY GOOD	VERY GOOD	VERY GOOD	<p>Honda’s ICEs are already among the most advanced in the industry, including 100% application of variable valve timing, wide application of low friction engine technologies, and the increasing application of variable cylinder management.</p> <p>Honda has plans in place to introduce an advanced lineup of new engines and transmissions under the banner of “Earth Dreams” technologies. The all-new, ninth-generation Accord applies a number of these technologies, including direct injection (DI), a continuously variable transmission (CVT), and two-motor hybrid system.</p>
	<p>There remain significant opportunities to further improve the fuel efficiency of the gasoline internal combustion engine (ICE).</p> <p>Fuel-efficiency improvements directly correlate with both GHG and petroleum reductions.</p> <p>Improved ICE presents the greatest short-to mid-term overall benefit to social values because of its existing high volumes and broad marketability.</p>			<p>The incremental costs of improving ICEs should be paid back by fuel savings over several years even under current, moderate fuel prices.</p> <p>Improved gasoline ICEs are proven to be appealing and well accepted by consumers.</p>				

## Improving Fuel Efficiency and Reducing Greenhouse Gas Emissions

	Social Values			Marketability				Honda's effort
	AIR QUALITY	GHG REDUCTION	ENERGY SECURITY	INFRA-STRUCTURE	COST	FULL FUNCTION	APPEAL	
<b>Natural Gas Vehicles</b>	<b>VERY GOOD</b>	<b>GOOD</b>	<b>VERY GOOD</b>	<b>CHALLENGING</b>	<b>FAIR</b>	<b>GOOD</b>	<b>GOOD</b>	<p>Honda launched a fourth-generation natural gas-powered Civic in October 2011. This new 2012 Civic Natural Gas delivers increased fuel efficiency and driving range.</p> <p>Honda began selling natural gas vehicles in 1998 to U.S. fleet customers, extending sales to retail customers in 2001. The company has steadily expanded its market footprint in the U.S. — and is marketing the new 2012 Civic Natural Gas to retail customers through nearly 200 Honda dealers in 37 U.S. states.</p>
	<p>Natural gas is an abundant, inexpensive, and domestic fuel.</p> <p>ICEs optimized for natural gas can produce zero particulate emissions (Air Quality) and 25% fewer CO<sub>2</sub> emissions (GHG Reduction) than a gasoline-powered vehicle.</p> <p>Since natural gas is a domestic alternative to petroleum, it is excellent for energy security.</p> <p>Continued attention should be paid to the methods of extracting natural gas to ensure there are no substantial negative environmental or public health impacts.</p>			<p>Public refueling stations remain the single biggest obstacle to the widespread adoption of natural gas vehicles.</p> <p>The cost premium for natural gas vehicles is roughly the same as that of a hybrid automobile, with the potential for further reductions. This cost premium can be offset by the lower fuel cost.</p> <p>Vehicle utility, such as cargo space, can be impacted by the space required for fuel storage.</p> <p>Natural gas vehicles offer performance, safety, and comfort on par with their gasoline counterparts.</p>				
<b>Diesel</b>	<b>GOOD</b>	<b>FAIR</b>	<b>GOOD</b>	<b>GOOD</b>	<b>FAIR</b>	<b>VERY GOOD</b>	<b>GOOD</b>	<p>Honda actively markets 2.2-liter i-DTEC™ diesel engine technology in Europe, where diesel fuel is priced significantly lower than gasoline.</p>
	<p>Modern diesel engines can meet stringent emissions standards.</p> <p>Diesel contains 13% more carbon than gasoline, therefore the CO<sub>2</sub> emissions reduction potential is less than the efficiency improvement, resulting in a score of “fair” for GHG reduction.</p> <p>Diesel engines offer up to 30% fuel-efficiency gains over current ICE technology, which is good for energy security.</p>			<p>Diesel engines typically cost significantly more than their gasoline version. In some markets diesel fuel is much cheaper than gasoline, so the fuel savings can pay for the incremental diesel engine cost. The price of diesel fuel in North America is, however, not less expensive than gasoline, and this is expected to continue into the future. Therefore, the added cost of the engines, together with the higher priced fuel, results in an overall higher cost.</p> <p>The reputation of diesel technology has improved in recent years with improvements in performance, emissions, and noise.</p>				
<b>Biofuels</b>	<b>VERY GOOD</b>	<b>CHALLENGING-VERY GOOD</b>	<b>GOOD</b>	<b>CHALLENGING-VERY GOOD</b>	<b>GOOD-VERY GOOD</b>	<b>VERY GOOD</b>	<b>FAIR</b>	<p>All Honda and Acura automobiles, as well as the company's motorcycle and power equipment products, are capable of operating using E10 (10% ethanol in gasoline). Honda is researching the feasibility of higher blends, including midlevel blends such as E15 or E20, for cars and light trucks only.</p> <p>In partnership with the Research Institute of Innovative Technology for the Earth (RITE) in Japan, Honda is conducting independent research into the efficient production of ethanol from cellulosic feedstocks.</p>
	<p>Depending upon their sources and their processes, the greenhouse gas emissions from biofuels vary significantly.</p> <p>Biofuels offer significant opportunities to reduce petroleum use, although the scalability and volume potential of biofuels is unclear, hence the “good” rating.</p> <p>The greatest challenge is achieving sustainable biofuel processes that minimize impacts on land, water, and food.</p>			<p>Infrastructure varies significantly: ethanol requires new infrastructure for the transportation of the fuel, however, some biofuels are “drop-in” fuels like bio-butanol or bio-diesel. Drop-in fuels have the potential to fit directly into existing infrastructure.</p> <p>Biofuels resulting in ethanol are less appealing to consumers since they must refuel more frequently due to less energy per gallon of fuel.</p>				

## Improving Fuel Efficiency and Reducing Greenhouse Gas Emissions

	Social Values			Marketability				Honda's effort
	AIR QUALITY	GHG REDUCTION	ENERGY SECURITY	INFRA-STRUCTURE	COST	FULL FUNCTION	APPEAL	
<b>Hybrid Electric Vehicles</b>	<b>VERY GOOD</b>	<b>GOOD</b>	<b>GOOD</b>	<b>VERY GOOD</b>	<b>FAIR</b>	<b>VERY GOOD</b>	<b>VERY GOOD</b>	<p>Honda pioneered hybrids in the U.S. and Canada with the launch of the Insight hybrid vehicle in 1999 and has sold more than 300,000 hybrid automobiles in North America. The company has steadily advanced its Integrated Motor Assist™ (IMA™) hybrid system to increase its efficiency and performance.</p> <p>Honda markets four distinct hybrid models in North America — the Insight, the CR-Z Sport Hybrid, the Civic Hybrid, and the Acura ILX Hybrid. A new generation Civic Hybrid was introduced in the spring of 2011, delivering the highest fuel economy (44 mpg EPA rated) of any sedan in the U.S., while increasing its appeal with respect to performance, comfort, customer-friendly technology, and safety. In 2013 Honda expects to launch a hybrid version of the all-new Accord using Honda's new two-motor hybrid system.</p>
<b>Plug-in Hybrid Electric Vehicles</b>	<b>VERY GOOD</b>	<b>GOOD</b>	<b>VERY GOOD</b>	<b>FAIR</b>	<b>CHALLENGING</b>	<b>GOOD</b>	<b>VERY GOOD</b>	<p>Honda is developing a new Accord plug-in hybrid that uses a new dual-motor hybrid system. The new plug-in hybrid vehicle is scheduled for launch in the U.S. in 2013.</p>

Hybridization can significantly increase fuel efficiency by using energy captured during deceleration and braking for motive power.

These significant improvements in efficiency directly result in significant GHG reductions and corresponding reductions in gasoline consumption (Energy Security).

The cost premium versus gasoline-only vehicles remains the most significant barrier to broader market appeal.

Hybrid automobiles are increasingly viewed as mainstream technology with a high level of appeal and with performance, safety, and utility virtually on par with conventional ICEs.

When measured on a wells-to-wheel basis, using the U.S. national electric grid, the GHG reductions are similar to a hybrid.

The GHG emission levels of the national electric grid limit the benefits of PHEVs. PHEVs use both gasoline and electricity. Both the on-board (gasoline) and remote (electricity) GHG emissions must be accounted for in the overall evaluation of PHEVs. Cleaning up the emissions from powerplants is a continuing challenge.

Using electricity generated off-board in place of petroleum results in reduced consumption of petroleum (Energy Security).

Although most PHEVs can utilize conventional 110 Volt AC electricity, a dedicated circuit is needed, in order to assure uninterrupted recharging. Additionally, not all consumers have consistent access to off-street parking with electricity in close proximity.

Cost remains a significant barrier to broader marketability. The incremental fuel savings between HEVs and PHEVs is not sufficient to offset the incremental PHEV costs, based on current battery costs.

Plug-in hybrids offer similar utility and performance to conventional hybrids.

## Improving Fuel Efficiency and Reducing Greenhouse Gas Emissions

	Social Values			Marketability				Honda's effort
	AIR QUALITY	GHG REDUCTION	ENERGY SECURITY	INFRA-STRUCTURE	COST	FULL FUNCTION	APPEAL	
<b>Battery Electric Vehicles</b>	<b>VERY GOOD</b>	<b>GOOD</b>	<b>VERY GOOD</b>	<b>CHALLENGING</b>	<b>CHALLENGING</b>	<b>CHALLENGING</b>	<b>VERY GOOD</b>	<p>Honda was the first to market an advanced battery electric vehicle in the U.S., the Honda EV Plus, between 1997 and 2003. The EV Plus used advanced NiMH batteries.</p> <p>Honda is leasing the Fit EV battery-electric vehicles to consumers in California and Oregon, expanding to East Coast markets in early 2013.</p> <p>The Fit EV has an EPA estimated combined city/highway driving range of 82 miles (adjusted label value) from its 20 kWh battery pack, capable of a full recharge at home in as little as three hours. The Fit EV is the most fuel-efficient EV on the market with a combined EPA fuel economy rating of 118 MPGe.</p>
								<p>When measured on a well-to-wheel basis, using the U.S. national electric grid, the GHG reductions are similar to a hybrid.</p> <p>Cleaning up the emissions from powerplants is a continuing challenge.</p> <p>BEVs substitute energy from the electric grid for petroleum consumption, enhancing energy security.</p> <p>BEVs require access to consistent, off-street parking and the installation of specialized charging equipment and 220V AC circuitry.</p> <p>Although electricity costs are significantly lower than gasoline costs on a per-mile basis, the higher, initial costs of advanced batteries remain a challenging obstacle to widespread consumer adoption.</p> <p>With respect to "full functionality," BEVs have limited range and re-charge time, and range can vary substantially based upon environmental conditions (temperature, humidity, etc.).</p> <p>BEVs offer quiet and responsive driving performance, which is appealing to many consumers.</p>
<b>Fuel Cell Electric Vehicles</b>	<b>VERY GOOD</b>	<b>VERY GOOD</b>	<b>VERY GOOD</b>	<b>CHALLENGING</b>	<b>CHALLENGING</b>	<b>VERY GOOD</b>	<b>VERY GOOD</b>	<p>Honda has had programs for consumer evaluation of the its FCEV technology, in operation since 2005.</p> <p>Honda's FCX Clarity packages Honda fuel cell technology in a full utility four-passenger sedan.</p> <p>Honda in 2015 will introduce a new FCEV in the U.S., Japan and Europe, that realizes a significant reduction in cost.</p>
								<p>On a well-to-wheel basis, most hydrogen pathways are extremely clean and hydrogen is identified by the California Air Resources Board as one of its ultra low carbon fuel pathways.</p> <p>Hydrogen can be sourced in many different ways, including from electrolysis and from reformed natural gas. Either of these two methods replaces petroleum.</p> <p>In the near term, the cost of fuel cell technology and the very limited refueling infrastructure remain significant barriers.</p> <p>Fuel cell vehicles deliver performance, utility, comfort, and driving range virtually on par with conventional gasoline-powered automobiles.</p>

## Improving Fuel Efficiency and Reducing Greenhouse Gas Emissions

The area of **Reduced Running Resistance** covers a broad range of technologies and approaches to lightweighting, aerodynamics, and friction reduction, and it is therefore difficult to characterize the value and marketability of the category.

Social Values			Marketability				Honda's effort
AIR QUALITY	GHG REDUCTION	ENERGY SECURITY	INFRA-STRUCTURE	COST	FULL FUNCTION	APPEAL	

### Reducing Running Resistance

Improved aerodynamic design, reduced tire rolling resistance, and lower vehicle mass can improve the fuel efficiency of any type of vehicle regardless of powertrain or energy source.

This has a positive effect on both GHG reduction and petroleum consumption.

Efforts to reduce running resistance must be taken into account with other factors, including vehicle cost, performance, safety, and utility, in order to meet the expectations of customers while simultaneously advancing the social benefits of new products.

Honda is continually researching new means of reducing vehicle running resistance while delivering on the performance, utility, and safety requirements its customers demand.

All new Honda and Acura vehicles introduced over the past several years have used increasing amounts of high-strength steel, which typically accounts for half or more of a new Honda or Acura vehicle's body structure, among the highest levels in the industry.

The company is continually exploring methods of reducing weight, including new materials and methods of body design, to allow for further reductions in weight while maintaining high levels of safety and customer value.

The company recently commissioned a new wind tunnel facility in Ohio that is designed to help engineers realize further improvements in aerodynamic efficiency at early stages of new vehicle development.

# Life Cycle Assessment

Honda recognizes Life Cycle Assessment (LCA) as a critical tool for understanding the impact of its products and operations on the environment, and is working to minimize that impact in virtually every aspect of its business.

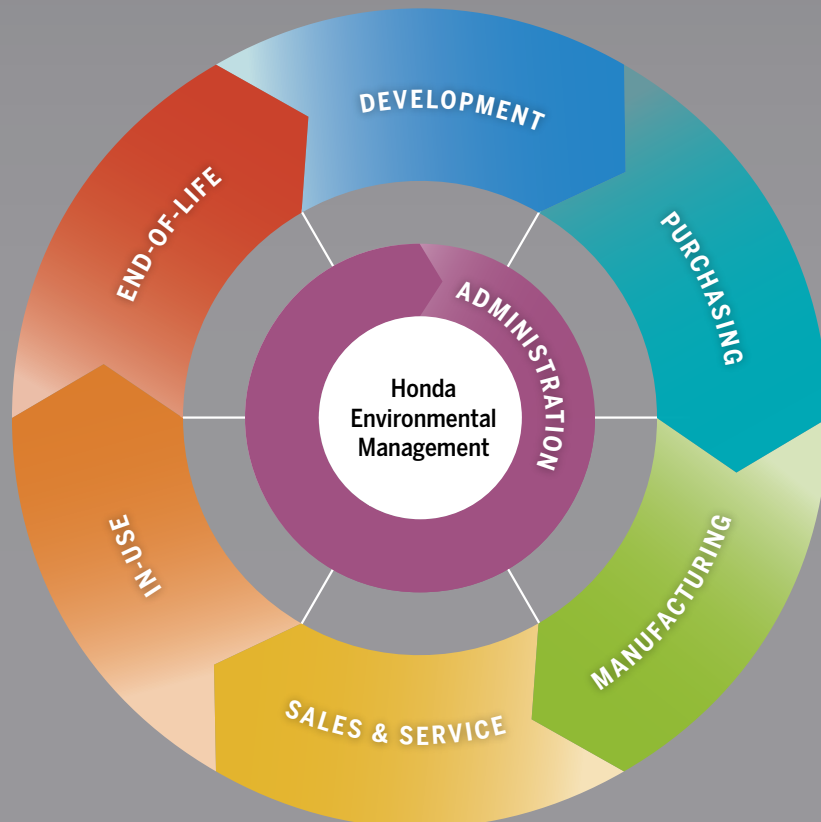

## Development

In-use and end-of-life impact of Honda products on the environment as a result of product design, including fuel efficiency; the use of virgin, non-recyclable, and potentially toxic materials; and the ease with which products can be effectively disassembled for recycling at the end of their useful life.

## Purchasing

Resource consumption, air emissions, toxic releases, and waste associated with the production of component parts manufactured by original equipment suppliers.

## Manufacturing

Resource consumption, air emissions, toxic releases, and waste associated with the production and final assembly of Honda products in Honda's own manufacturing plants.

## Sales & Service

Emissions and waste from the effort to support the sales and servicing of Honda products in the marketplace, including the shipment of service parts and finished products between suppliers, warehouses, and dealers.

## In-Use

Greenhouse gas and smog-forming emissions from the use of Honda products in the hands of customers, impacted significantly by product fuel efficiency and tailpipe emissions performance.

## End-of-Life

Waste and toxic emissions from the disposal of Honda products and parts at the end of their useful life.

## Administration

Energy consumption, emissions, and waste resulting from the operation of Honda's offices and warehouse facilities.



Life Cycle Assessment

# Product Development

## Overview

The reduction of Honda's environmental footprint begins with the development of products that use fuel more efficiently, contain fewer substances believed to be harmful to the environment, and are designed to be manufactured using fewer scarce or non-recyclable materials, along with improved ease of dismantling to accommodate the recycling of materials at the end of a product's useful life.

## Focus

The single largest impact of Honda's products on the environment comes from the consumption of non-renewable fossil fuels and the byproducts of fuel combustion, including CO<sub>2</sub> emissions that contribute to global climate change. Honda is pursuing further advances in product fuel efficiency as the core of its commitment to reducing the environmental impact of Honda products.



## Design for the Environment

Environmental factors are considered early and in each phase of the design and development process of every Honda and Acura product. In component design and in the selection of materials, Honda looks for opportunities to reduce a product's total environmental footprint, including its impact at the end of its useful life. Accordingly, Honda engineers take into account such factors as dismantling complexity, component remanufacturing, and the minimization of substances of concern (SOCs).

## Product Recyclability

In accordance with its global standard for the development of Honda products, the company has achieved and is committed to maintaining a minimum 90% level of design recyclability<sup>1</sup> for all Honda and Acura automobiles, and a minimum 95% level of design recyclability<sup>1</sup> for all powersports and power equipment products sold in North America. As of 2004, all new Honda and Acura automobiles have met or exceeded the 90% target. Honda will continue to look for new ways to improve the design recyclability of future products, in balance with other critical considerations, such as quality, efficiency, cost, and durability.

<sup>1</sup> Honda's calculation of product recyclability is based on the ISO standard 22628, titled "Road Vehicles Recyclability and Recoverability Calculation Method," which bases its estimates on existing, proven treatment technologies and takes into account the mass of materials recycled, reused, recovered for energy, or otherwise diverted from landfill disposal. In addition to these guidelines, Honda's calculation also takes into account recyclable mass within nonmetal residue.

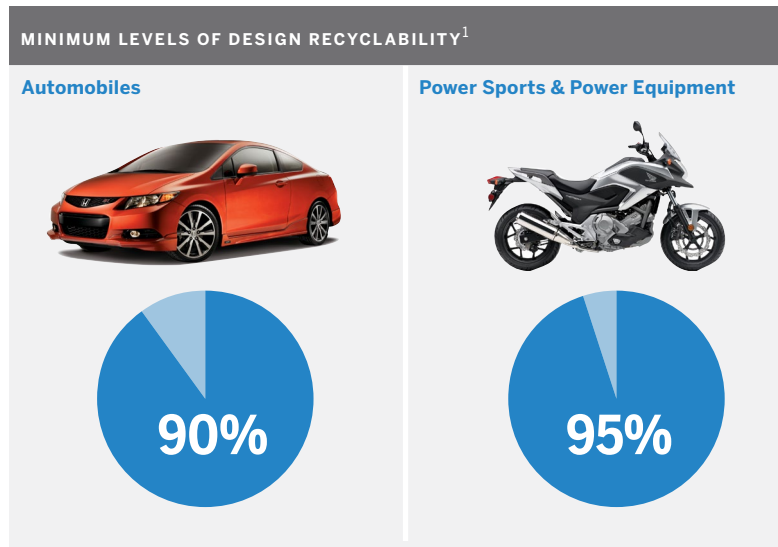



## Reducing Substances of Concern (SOCs)

Honda's efforts to reduce SOCs have been consistent with evolving government regulations. The tools detailed below will help the company better understand and track the presence of SOCs in its products. Further, it will enable the company to continue to reduce the negative environmental impact of its products throughout their life cycle. This information will be essential as society moves toward a more comprehensive approach to chemical management and green chemistry.

### Supplier SOC Management Manual

Honda's Supplier SOC Management Manual documents the company's expectations for all producers of parts and materials used in Honda's products with respect to SOCs and recyclability. The Supplier SOC Management Manual is updated annually to reflect the latest regulatory and reporting requirements, Honda's SOC policies, and regional expectations. All suppliers are expected to reference the Manual for pertinent information regarding Honda's chemical management policies.

### Compliance with Hazardous Material Regulations

Honda continues to monitor on a global basis regulations that impact products produced in North America. During FY11, Honda, with the cooperation of its supply base, has worked to gather material data on all parts and products bound for nations with hazardous material regulation requirements. Honda has focused on the REACH regulations, as well as reductions in the use of deca-BDE in the United States. Working with the supply base for Honda automobile, all-terrain vehicles and power products, Honda has successfully identified the parts using this chemical and has worked with the suppliers to eliminate the usage in their mass production manufacturing process.

- **Continuing Use of International Material Data System (IMDS)**  
On a global basis, starting in April 2010, Honda began to receive material data sheet submissions in IMDS from the supply base. IMDS is being used to gather data for all Honda divisions: automobile, powersports, and power equipment. Honda is tracking the use of chemicals in its company-wide system, which registers and classifies chemical substances. All suppliers providing products to any Honda manufacturing entity, as well as suppliers of service parts, will be required to enter material data into IMDS. All suppliers of parts and materials procured by Honda are required to provide comprehensive data on the chemical composition of parts and materials.
- **Honda Chemical Management Standards**  
The Honda Chemical Management Standard is used globally to identify those chemicals that should no longer be used, those chemicals for which a phase-out period has been identified, and those chemicals that Honda is monitoring for potential elimination. The Honda Chemical Management Standard addresses automotive, powersports, and power equipment requirements. Honda is committed to reducing and, if possible, eliminating SOCs in all products, in accordance with global regulations.
- **Compliance with REACH**  
In accordance with Honda's efforts to manage chemical substances in its products, the company has worked with its supply chain to guarantee compliance with the European Union's REACH (Registration, Evaluation, Authorization, and Restriction of Chemicals) regulation for products sold in North America. Honda has worked with its suppliers to understand chemical breakdown of current parts and materials. Together, the targeted Honda manufacturing facilities and the North American supply chain have been responsive and accountable to the REACH regulation. This enables Honda to ascertain the content percentage amount of the substances at the article level to confirm and report compliance.

## Reducing Substances of Concern (SOCs) cont'd

Substances of Concern in Honda and Acura Products	
CURRENT STATUS	OPPORTUNITIES FOR FUTURE REDUCTIONS
<b>Lead</b> — used in electronic applications for its good melting characteristics, long-term stability, and vibration durability. Used in metal alloys for its superior machinability, strength, and fatigue resistance.	
Reducing use in electronics, light bulbs, and corrosion-resistant paints.	Working with individual suppliers to introduce lead-free circuit boards that meet Honda's requirements for durability and performance.
Replaced lead with non-hazardous materials in electro-deposition coatings and steel bars (with the exception of residual amounts of contaminants that may include lead, such as lead in recycled aluminum).	Overcoming strength and fatigue when lead inclusions in the microstructure of the steel alloys are replaced with manganese sulfide (MnS) inclusions.
Eliminated from automobile and on-highway motorcycle wheel weights; replaced with a zinc alloy.	Introduced low-lead ATV wheel hubs in 2012. Trace amounts of lead in steel and recycled aluminum may still be present. Honda chemical substance guidelines allow for a maximum 0.25% lead content by volume.
<b>Hexavalent Chromium</b> — used to protect exterior parts from corrosion.	
All North American suppliers have phased out the use of hexavalent chromium.	Fully eliminated. Continue to monitor suppliers for compliance.
<b>Mercury</b> — used for bright and uniform illumination.	
Honda has never used mercury in switches, radios, or ride-leveling devices. However, Honda still uses very small quantities of mercury in high-intensity discharge (HID) headlights and in illuminated entertainment and navigation systems.	Phasing in mercury-free displays using a new type of backlight, beginning with new models introduced in model year 2010.  Start to employ mercury-free HID bulbs within the next several years, as the remaining technical challenges are overcome.
<b>Polybrominated Diphenyl Ethers (PBDEs)</b> — used as a flame retardant and as a surfactant.	
Phased out the use of octa- and penta-PBDEs in 2004. Working with suppliers to verify that these substances are no longer used in products. A small number of original equipment parts still contain PDBEs.	Working with suppliers to eliminate deca-BDEs from products when technically feasible. Honda phased out deca-PDBEs from all ATV and off-road motorcycles in 2011.
<b>Perfluorooctane Sulfonate (PFOS)</b> — used as a water repellent agent.	
Eliminated PFOS in all parts delivered to North American manufacturing facilities.	Fully eliminated. Continue to monitor suppliers for compliance.
<b>Polyvinyl Chloride (PVC)</b> — used in sealants and interior materials to reduce weight and to meet high standards for durability, fade resistance, and other critical quality criteria.	
Replacing PVC used in instrument panels, inner-door weather stripping, and shift knobs.	Working with suppliers to implement PVC-free technologies for components such as interior trim pieces and seat coverings.



---

## Reducing PVC in Honda and Acura Automobiles

---

Honda's goal is to have a PVC-free material construction for interiors on all of its vehicles. Through the end of FY12, vehicles with PVC-free interiors are the Honda Accord Coupe & and Accord Sedan, Crosstour, Odyssey, CR-Z, Insight, and the Acura TL, RDX, ILX, ZDX, and RL.

Honda continues to investigate high-quality and cost-effective alternatives to PVC in an effort to minimize its use in all products. Although Honda has minimized the number of vehicle parts containing PVC, cost and quality barriers present a challenge to its total elimination.

---

## Air Quality/Cabin VOC

---

In line with Honda's strategy to reduce hazardous materials wherever possible, Honda is also focusing on the improvement of air quality within the interior of the vehicle. Honda engineers have been focusing efforts toward adequately measuring and predicting levels of in-cabin VOCs. This activity resulted in a better understanding of which parts Honda engineers should focus on to help reduce in-cabin VOC levels.

- Several low in-cabin VOC technologies, such as low-VOC adhesives, tapes, foams, and coating materials, have been applied to Acura and Honda models since the launch of the 2008 Accord in the fall of 2007. Recently redesigned vehicles, such as the 2011 Odyssey and 2012 Civic, have included new non-painted, high-quality appearance low-VOC plastic materials for the inner door handles.
- Honda will continue its efforts to reduce cabin VOCs and to improve air quality in the cabins of all its vehicles.

## New Products and Technologies Introduced in FY12

### Automobiles

#### New 'Earth Dreams Technology' Powertrains

In FY12, Honda announced a new series of powertrain technologies to be marketed under the 'Earth Dreams' technology moniker. These include more fuel-efficient gasoline engines, a newly developed continuously variable transmission (CVT), a two-motor hybrid system, and high-efficiency, high-output Sport Hybrid Super Handling All-Wheel Drive (Sport Hybrid SH-AWD) system. The first application of this new technology is in the all-new, ninth generation of the Accord, Honda's best-selling model in North America, and the Crosstour crossover, both of which were introduced in the fall of 2012. The new Sport Hybrid SH-AWD system will be first applied to the Acura RLX flagship sedan, debuting in 2013.



#### More Fuel-Efficient Gasoline Engines

By enhancing Honda's original VTEC (Variable Valve Timing and Lift Electronic Control System) technology to improve thermal efficiency and minimize friction, Honda developed a new engine series in a wide range of engine classes, including the 660cc, 1.5-liter, 1.8-liter, 2.4-liter, and 3.5-liter classes. A new 4-cylinder engine architecture, to be applied to the new Accord, employs a die-cast aluminum block for reduced weight and a high-pressure direct injection fuel system along with other



technologies to achieve a 12% increase in torque and 11% increase in fuel economy.

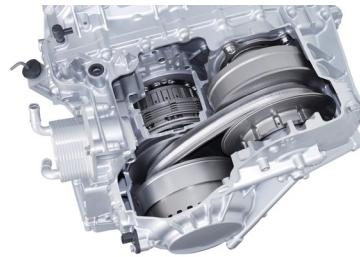

#### Continuously Variable Transmission (CVT)

A new Continuously Variable Transmission (CVT) has been designed to be adopted in a variety of engines and models. This new Honda CVT uses reinforced belts to enable wider gear ratios for greater efficiency.

Also, a new "G-design shift" control system is employed to provide for more precise and immediate response, improving power delivery and significantly mitigating the "rubber band" feel of earlier CVT systems.

#### Two-Motor Hybrid System

A new two-motor hybrid system has been developed to meet the growing need for CO<sub>2</sub> emissions reduction and enhance driving pleasure among owners of mid-sized and larger vehicles as well. Three driving modes allow for top-level industry efficiency in various driving environments: an EV mode for urban environments, a hybrid mode using electricity generated by the motor, and an "engine-connected" mode where the engine and wheels are mechanically connected during high-speed cruising. In addition, the system employs a dedicated lithium-ion battery, charger, and other parts to enable easy application on plug-in hybrid vehicles. Honda will introduce this new system in North America, first on a plug-in hybrid version of the new 2013 Accord, in early 2013, followed by a conventional (non plug-in) hybrid Accord model later in 2013.

Two-motor hybrid system operating modes

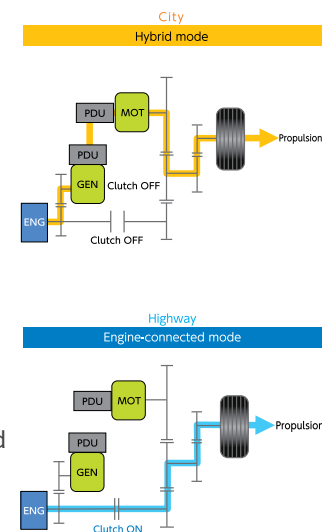

PDU: Power Drive Unit  
MOT: Motor  
GEN: Generator  
ENG: Engine

## New Products and Technologies Introduced in FY12 cont'd

### Sport Hybrid SH-AWD

A new high-efficiency, high-output electric Sport Hybrid Super Handling All-Wheel Drive (SH-AWD) hybrid system combines superior driving and environmental performance. The system employs an electric all-wheel drive system with two independent 20-kilowatt motors driving the rear wheels and a 7-speed dual clutch transmission system with a built-in 30-kilowatt high-efficiency motor and high-efficiency V6 engine driving the front wheels. This system, to debut in North America in 2013 on the Acura RLX flagship sedan, takes driving pleasure and environment friendliness to an all new level through advanced handling and acceleration equivalent to conventional V-8 engines, with fuel economy on par with an in-line 4-cylinder engine.

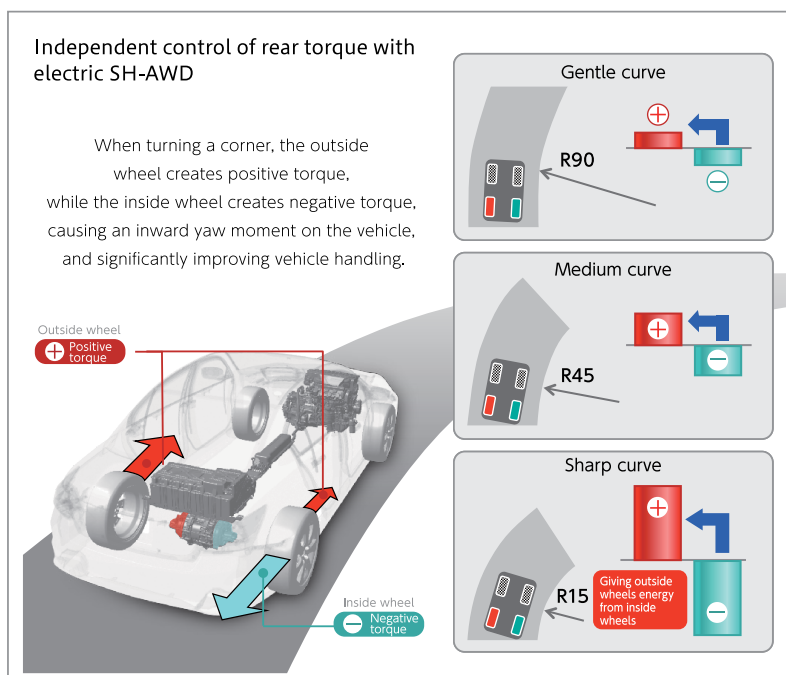

### Compact High-Efficiency Drive Train for Electric Vehicles

Honda began leasing its Fit EV dedicated electric vehicle to consumers in Southern California and Oregon in July 2012. The Fit EV achieves an industry-leading 118 MPGe combined city-highway fuel-economy rating<sup>1</sup> from the U.S. EPA. The Fit EV employs Honda's new EV powertrain, utilizing a high-efficiency 92-kilowatt (123-horsepower) co-axial motor, low-friction gear box, and electric servo brake system to achieve a top level of energy consumption rating of 29kWh/100<sup>1</sup> miles and an estimated driving range of 82 miles.<sup>1</sup> Additionally, the Fit EV can be recharged in less than three hours from a low-charge indicator illumination point when connected to a 240-volt circuit.

<sup>1</sup> 132/105/118 city/highway/combined miles per gallon of gasoline-equivalent (MPGe) rating; 82 mile combined (city/highway) driving range rating (adjusted). Ratings determined by U.S. EPA.

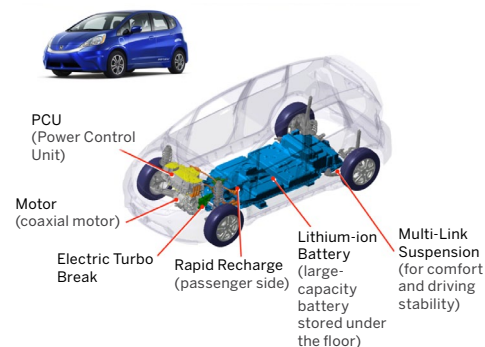

### New Honda CR-V Crossover SUV



In November 2011, Honda introduced a redesigned CR-V with a new 2.4-liter i-VTEC 4-cylinder engine that achieved a significant increase in fuel economy while delivering enhanced power and utility in the compact SUV class. The 2012 CR-V achieves an EPA

fuel economy rating of 23/31/26 mpg city/highway/combined, an increase of 1/3/2 mpg compared to the previous model. The CR-V also features a selectable ECON Mode that alters the operating characteristics of the vehicle to support an efficient driving style.



## New Products and Technologies Introduced in FY12 cont'd

### Powersports Products

#### NC700X Motorcycle with New 700cc Engine and DCT Transmission



In January 2012, Honda introduced the new 2012 Honda NC700X motorcycle, offering a unique blend of style, handling, and power. The NC700X is powered by a new Honda 700cc engine, a liquid-cooled overhead camshaft (OHC) in-line 2-cylinder engine that was designed based on a new concept for fun, comfortable, and fuel-

efficient riding. The new engine is mated to either a 6-speed gearbox or automatic dual-clutch transmission (DCT) with a Combined Anti-Lock Braking System. The fuel economy of the new engine achieves a 40%<sup>1</sup> increase in fuel economy compared to conventional engines in the same class of motorcycle.

<sup>1</sup> Based on Honda test data.

### Power Equipment Products

#### New Snowblowers See Fuel-Efficiency Upgrades



Honda introduced a series of new and improved snowblowers — two single-stage rotary models and four two-stage hybrid models with enhanced snow-clearing performance and maneuverability. The new GX engines used in the single-stage models employ a Digital Capacitive Discharge Ignition

(CDI) variable timing electronic ignition system for optimal ignition timing, higher compression ratios, and optimized carburetor settings for enhanced combustion efficiency. These upgrades translate into a 9% effective fuel-efficiency improvement<sup>1</sup> from earlier GX models with the same engine displacement. The new iGX (i-GX390), used in the new two-stage snowblower models, offers a 19% improvement<sup>1</sup>

from earlier GX models with the same engine displacement thanks to its i-governor system. These emission levels are far lower<sup>2</sup> than the standards set by the U.S. Environmental Protection Agency's (EPA) Phase 3 regulations,<sup>3</sup> the most stringent emission regulations for small non-road engines in the world.

<sup>1</sup> Honda internal research (approximately 25% less for GX390 and iGX390 and 30% less for GX270 and iGX270 operating in EPA standard test mode).

<sup>2</sup> Honda internal research (approximately 25% less for GX390 and iGX390 and 30% less for GX270 and iGX270 operating in EPA standard test mode).

<sup>3</sup> Effective January 2011.

#### Honda EB10000 Series Generator Powered by Updated GX630 Engine

The new EB10000 Industrial Series generator — the largest generator in Honda's lineup, with a maximum output of 10,000 watts — is compact, lightweight, and features a wide range of design innovations that contribute to exceptional fuel economy while maintaining high



operating power performance. These include a narrow frame design for maneuverability, a centralized exhaust mechanism, and a newly developed alternator. The Honda GX630 engine that powers the EB10000 offers higher fuel economy than competing models, and reduced emissions via an advanced combustion chamber design and the implementation of digital Capacitive Discharge Ignition (CDI) with variable ignition timing and twin-barrel inner-vent carburetion. In addition, the EB10000 is OSHA, LA-ETL, CARB, EPA Phase III (without the use of a catalyst), and USDA compliant. The new Honda Industrial Series model operates at an extremely quiet noise level — approximately 72 decibels at 23 feet (equivalent to the noise of a vacuum cleaner). This low noise level is achieved, in part, through an improved muffler that includes a punching pipe, a perforated mechanism that allows for the smooth release of exhaust gas.



Life Cycle Assessment

# Purchasing

## Overview

Our approach to environmental management extends to approximately 600 original equipment parts manufacturers (OEMs) and parts logistics companies that supply Honda operations in North America. Environmental impacts include material waste, consumption of natural resources, substances of concern, and greenhouse gas emissions, predominantly CO<sub>2</sub> from the production of component parts and the consumption of fuel to transport parts from suppliers to Honda plants.

## Focus

We encourage suppliers to adopt measures to reduce the environmental impact of producing parts and components for Honda and Acura products, focusing on energy use, emissions, regulated substances, and packaging waste. At the same time, we continually work in close partnership with suppliers and logistics companies to reduce the environmental impact from parts transportation through initiatives that include route consolidation, use of on-site consolidation centers to reduce shuttle traffic, and optimization of shipping transport space.

## Honda “Green Purchasing” Guidelines

Aiming to achieve a global low-carbon society, Honda established the Honda “Green Purchasing” Guidelines in 2001 to guide our environmental conservation activities in the area of purchasing. Honda’s North American Purchasing group worked with Honda’s parent company, Honda Motor Co., Ltd., to revise its guidelines in January 2011, focusing on better tracking and reducing the environmental impact throughout the supply chain beyond primary suppliers.

The Honda “Green Purchasing” Guidelines apply to all parts and materials suppliers around the world. The Guidelines consistently communicate Honda’s expectations to all suppliers so we can offer customers worldwide products with a minimal environmental footprint. Working in partnership with our suppliers, we are continuing to take measures to reduce our environmental footprint.

### The Supply Chain environmental initiatives include:

- 1 Environmental management activities to ensure environmental control for products (parts and materials) and corporate activities.
- 2 Environmental activities to reduce greenhouse gas emissions in all corporate areas.
- 3 Parts and material proposals focusing on environmental issues to achieve weight reduction, lower rolling resistance, and energy usage reduction.
- 4 Complying with laws and regulations, and assuring compliance with the Honda Chemical Substance Management Standard.

### Supplier Sustainability and Greenhouse Gas Initiative

Honda is continuing its efforts to better understand the carbon footprint of its supply chain in North America. In FY11, Honda led a pilot program with a select group of suppliers to develop a more complete picture of the challenges associated with the tracking and reporting of greenhouse gas emissions data in our supply chain. The targeted suppliers represent a high percentage of Honda’s annual procurement spending. The responses from target suppliers provide essential data concerning supplier readiness, risk management, and knowledge level within the supply chain. Moving forward, Honda will continue to engage more suppliers in this activity.

## Parts Logistics Initiatives Reduce Fuel Consumption and CO<sub>2</sub> Emissions

### Optimizing Honda's Dynamic Delivery Conditions

As customer demand for specific models and volumes change, Honda must adjust its parts shipping logistics strategy to remain optimally efficient and minimize its environmental impact.

In addition to the nearly monthly re-engineering of the transportation network, daily activities are conducted to improve the utilization of available trailer space (cube utilization) to eliminate empty delivery miles.

Cube Utilization Efforts		
ACTION	FY11 RESULTS	
	TRUCK MILES AVOIDED	CO <sub>2</sub> EMISSIONS AVOIDED
<b>Daily load planning</b> to ensure material arrives at its required time while achieving fully cubed trucks.	733,000 miles	2.52 million pounds
<b>Dynamic releasing</b> of small-volume orders onto available trailer space in Honda's network to avoid under-cubed trailers.	182,000 miles	620,000 pounds
<b>Continuous evaluation</b> to identify and act upon opportunities for optimized cube utilization, such as pulling ahead freight from Saturday production dates or non-aligned holidays when not all of Honda's plants run, adding non-OEM freight to the available cube, and even combining and eliminating routes.	924,000 miles	3.17 million pounds

### Supplier Symposium

Honda's North America Purchasing group holds an annual Environmental, Safety, and Ergonomics Symposium, where Honda recognizes the 'Green Factory Environmental Achievement' of its suppliers. At the 19th annual symposium, five North American parts suppliers were recognized for having excelled at conserving natural

resources, reducing energy use, and eliminating waste to landfills. In addition to receiving recognition for top environmental achievements, the suppliers attended seminars and roundtable sessions on environmental topics that included everything from energy and waste reduction to environmental compliance.



Life Cycle Assessment

# Manufacturing

## Overview

Honda operates 14 manufacturing facilities in North America, producing<sup>1</sup> automobiles, all-terrain vehicles (ATVs), and power equipment products such as lawn mowers, snow blowers, and small displacement general-purpose gasoline engines. In FY12, approximately 85% of the vehicles sold in North America were produced in the region.

## Focus

Our work to reduce the environmental impact of our manufacturing operations in North America includes efforts to reduce the energy intensity of production, as well as initiatives to use water and other natural resources more efficiently, and to reduce air emissions and waste generation.

---

**Important note concerning this section:** It is important for readers to understand the difference in scope of manufacturing data reported in the 2012 North America Environmental Report and the Honda Environmental Annual Report 2012 produced by Honda Motor Co. Ltd. in Japan. The Honda Environmental Annual Report 2012 reports data from all Honda Motor Co. Ltd. consolidated subsidiary and affiliated manufacturing operations in North America. The 2012 North America Environmental Report manufacturing data reports only data from the ten subsidiary operations currently producing products. Two additional manufacturing subsidiaries, Honda Aircraft Company Inc. and Honda Aero Inc., are not currently included because they have had no commercial sales. The CO<sub>2</sub> emissions, energy use, waste generation, and water use data reported in the 2012 North America Environmental Report has been independently verified by Bureau Veritas.

<sup>1</sup> Using domestic and globally sourced parts



## Production Activity in North America

Improving economic conditions resulted in more stability and an increase in production throughout the auto industry in FY12 versus the previous fiscal year; however, production at Honda's auto plants in North America were severely disrupted due to the earthquake and tsunami in Japan on March 11, 2011, and severe flooding in Thailand in the fall of 2011. Damage to many plants

severely curtailed the supply of parts to Honda plants through the end of CY11.

Due to the fact that manufacturing systems must remain in operation whenever production is taking place, these reduced production levels at some plants had a negative effect on per-unit measures of energy use, CO<sub>2</sub> emissions, waste, and water use.

### Honda Product Manufacturing Results in North America (millions of units)

**AUTOMOBILE PRODUCTION TOTALS**



**POWERSPORTS PRODUCTION TOTALS**

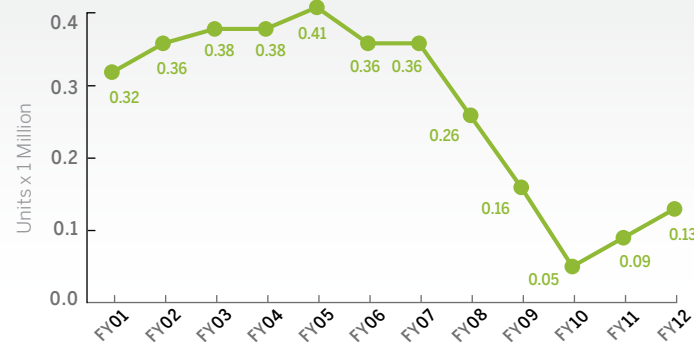

**POWER EQUIPMENT PRODUCTION TOTALS**

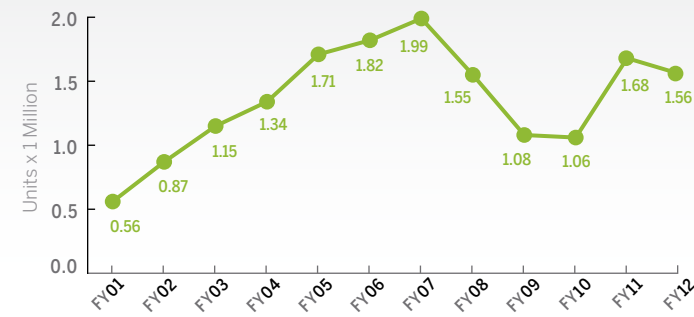

**ISO 14001 Certification of Manufacturing Facilities:** Honda implemented the central element for environmental oversight and management of its North American manufacturing operations in 1998 by making a commitment to achieve and maintain third-party ISO 14001 certification for environmental management at Honda manufacturing operations throughout the region. Thirteen of the 14 Honda plants operating at the end of FY12 were certified to the ISO 14001:2004 standard. Honda Manufacturing of Indiana, LLC, the company's newest auto plant in the region, is scheduled to achieve certification by 2014.



## CO<sub>2</sub> Emissions

Approximately 96% of CO<sub>2</sub> emissions from manufacturing operations in North America fall into two categories: (1) indirect emissions from the production of electricity purchased and consumed by Honda factories; and (2) direct emissions from their consumption of natural gas. Honda plants use electricity for automation, lighting, motors, air compressors, and cooling. Natural gas is needed for heating and conditioning fresh air, and for manufacturing process equipment such as melt furnaces and paint curing ovens.

Reduced production levels due to the impact from the Japan earthquake and flooding in Thailand continued to affect the energy efficiency of operations in FY12. Production levels remained below levels prior to the economic crisis of late 2008 and 2009. Much of the loss of efficiency from ongoing reduced production volumes was offset by continuing strong efforts to ensure that production equipment was shut down when plants were not operating.

### CO<sub>2</sub> Emissions from Manufacturing in North America

#### SOURCES OF CO<sub>2</sub> EMISSIONS

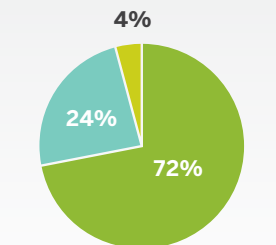

- **72%** Electricity
- **24%** Natural Gas
- **4%** Other Fuels  
Propane, fuel oil, gasoline, coke, kerosene

#### CO<sub>2</sub> EMISSIONS FROM MANUFACTURING (FROM PURCHASED ELECTRICITY AND NATURAL GAS)<sup>1</sup>

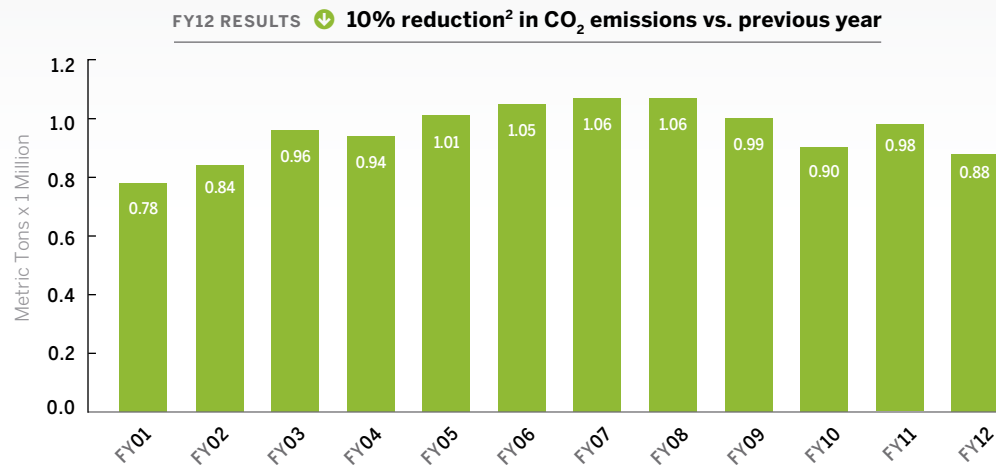

<sup>1</sup> Total CO<sub>2</sub> emissions (from consumption of electricity and natural gas) include the 14 listed North American manufacturing operations.

<sup>2</sup> 80% of the decrease in total CO<sub>2</sub> emissions in FY12 was due to the adjustment of electricity emission factors to eGRID2012 Version 1.0 Year 2009 Annual Output Emission Rates.

## CO<sub>2</sub> Emissions

### Per-Unit CO<sub>2</sub> Emissions (Emissions Intensity)

#### AUTOMOBILE MANUFACTURING<sup>1</sup>

##### FY12 RESULTS

- ↓ **2.0% vs. baseline (FY01)**
- ↓ **4.5% vs. previous year**

Reductions from the FY01 baseline and previous fiscal year were due largely to updating of the electricity emissions factor<sup>3</sup>.

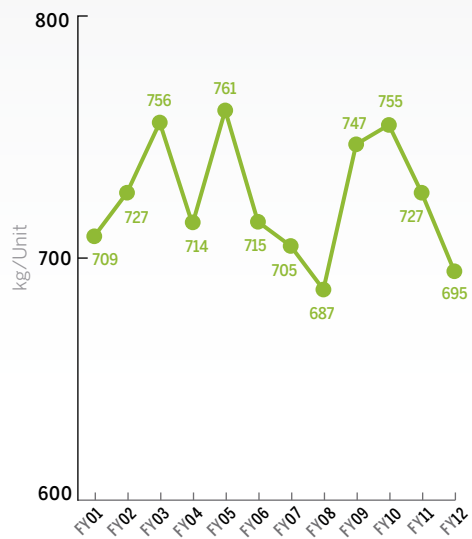

<sup>1</sup> CO<sub>2</sub> emissions data for automobile production prior to FY06 include production of both motorcycles and automobiles in Honda's plants in Mexico. Beginning with FY12 data, emissions at the Mexico plants are allocated between automobile and motorcycle production based on sales value.

#### POWERSPORTS PRODUCT MANUFACTURING<sup>2</sup>

##### FY12 RESULTS

- ↓ **22% vs. baseline (FY01)**
- ↓ **65% vs. previous year**

Reductions from the FY01 baseline were due largely to updating the electricity emissions factor<sup>3</sup> and discontinuing production of large motorcycles in North America.

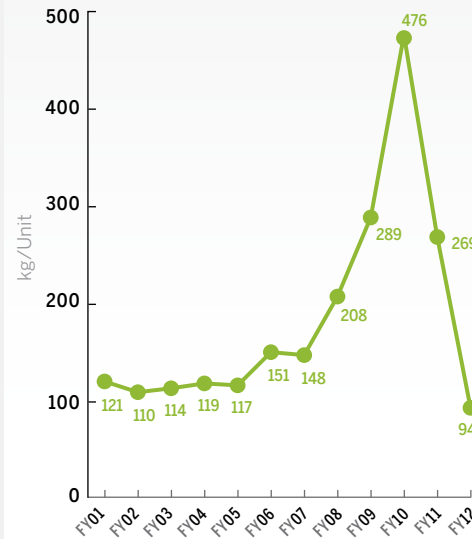

<sup>2</sup> CO<sub>2</sub> emissions data prior to FY06 do not include production of motorcycles in Mexico because the data were included in the automobile total. Beginning with FY12 data, emissions from plants in Mexico are allocated between automobile and motorcycle production based on sales value.

#### POWER EQUIPMENT PRODUCT MANUFACTURING

##### FY12 RESULTS

- ↓ **38% vs. baseline (FY01)**
- ↓ **12% vs. previous year**

Reductions from the FY01 baseline and previous fiscal year were due largely to updating the electricity emissions factor<sup>3</sup>.

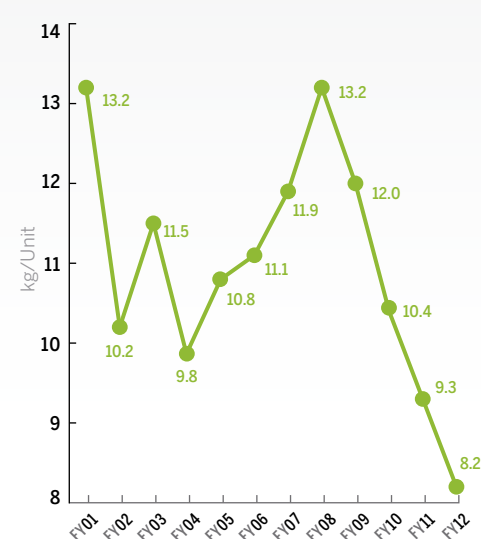

<sup>3</sup> Updated to eGRID2012 Version 1.0 year 2009 GHG Annual Output Emission Rates.

## Energy Use

Electricity and natural gas represent approximately 95% of total energy consumption by Honda's North American manufacturing plants.

Honda experienced two significant periods of disruption in its automobile production as a result of the earthquake and tsunami in Japan in March 2011 and flooding in Thailand in the fall of 2011,

both of which caused severe damage to many plants supplying Honda with parts. Honda was able to offset much of the potential loss in efficiency through the optimization of production schedules and continuing strong efforts to ensure that production equipment was shut down when plants were idle.

### Energy Consumption

#### ENERGY USE BY SOURCE

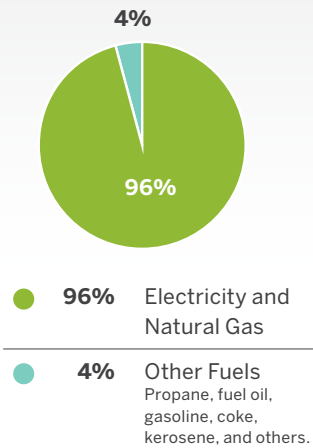

#### ENERGY USE IN MANUFACTURING (TOTAL AND PER AUTO)

##### FY12 RESULTS

##### Total Energy Use:

- ⬆️ 9.2% increase vs. baseline (FY01)
- ⬇️ 4.4% reduction vs. previous year

##### Energy Use Per Auto:

- ⬇️ 4.4% reduction vs. baseline (FY01)
- ⬆️ 2.7% increase vs. previous year

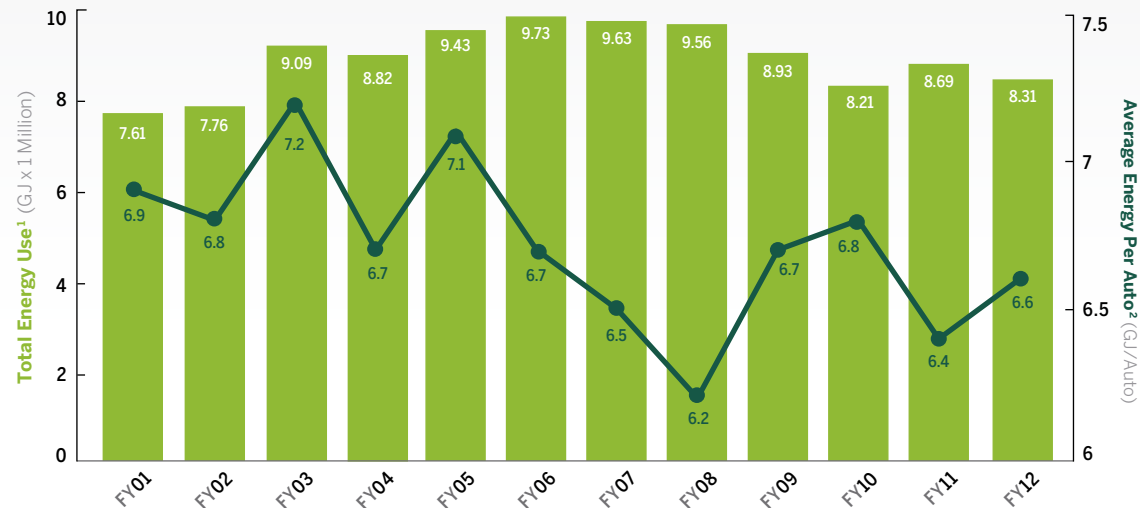

<sup>1</sup> Total energy use (from consumption of electricity and natural gas) includes all North American manufacturing operations.

<sup>2</sup> Energy used per auto encompasses all auto-related manufacturing activity, including automobile engines and transmissions produced in North America; it does not include power equipment and powersports products.



## Waste

Honda strives to prevent the generation of waste at its manufacturing plants, viewing it as inefficient use of raw materials. While Honda has nearly eliminated waste sent to landfill (see following page), the company continues to produce a small amount of waste in its manufacturing operations that it seeks to dispose of in the most environmentally sound manner.

Honda has created a waste management hierarchy that ranks waste management methods based on environmental preference (see illustration below). Use of a waste for energy recovery is preferable to landfill, and recycling/reuse is preferable to energy recovery. Honda's management strategy is based on this hierarchy along with the distinct characteristics and regulatory requirements associated with each waste product.

### Waste from Manufacturing Operations

#### TOTAL SOLID WASTE FROM MANUFACTURING IN NORTH AMERICA

##### FY12 RESULTS

##### Total Solid Waste:

↓ 5.1% reduction  
vs. previous year

##### Solid Waste Per Auto:

↑ 2.6% increase  
vs. previous year

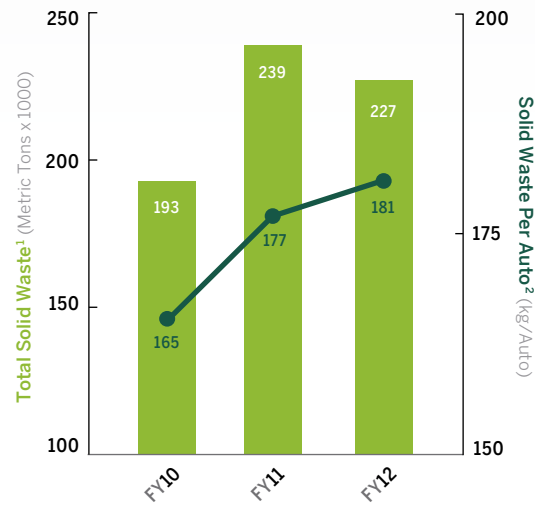

#### WASTE MANAGEMENT HIERARCHY

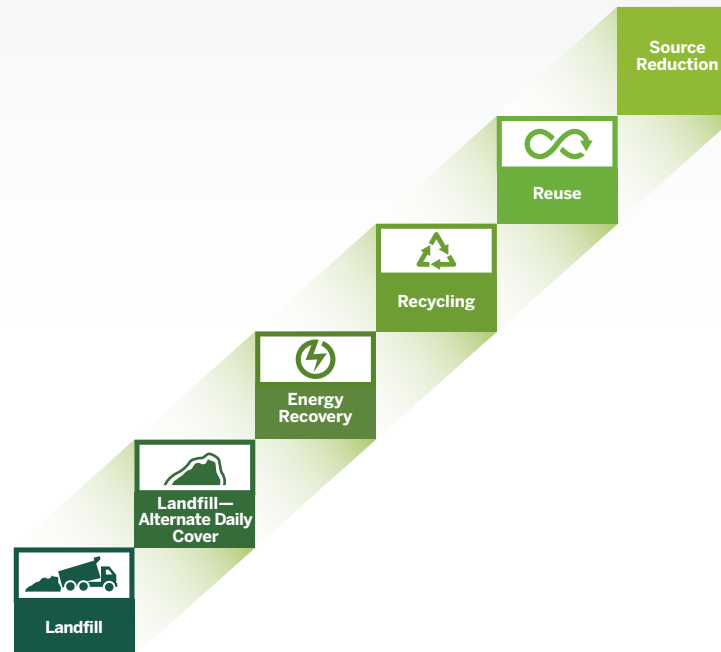

<sup>1</sup> Total waste includes the 14 listed North American manufacturing operations.

<sup>2</sup> Total waste per auto includes all auto-related manufacturing operations; it does not include powersports and power equipment production operations. Beginning with FY12 data, waste at the Mexico plants is allocated between automobile and motorcycle production based on sales value.

Waste cont'd

Honda set a target in FY09 to achieve virtually zero waste to landfill — defined as less than 1% of all operating waste, including mineral waste, sent to landfills — at all 14 of its North American manufacturing facilities by April 1, 2011. The target was achieved in FY11, with 10 of 14 plants achieving absolute

zero waste to landfill and total waste to landfill for all 14 plants being reduced to less than 0.5% of all manufacturing waste. Honda will continue to eliminate remaining waste to landfill where technically, economically, and environmentally feasible alternatives are identified.

Honda Zero Waste to Landfill Initiative

LANDFILL WASTE FROM MANUFACTURING FACILITIES IN NORTH AMERICA

FY12 RESULTS

Total Landfill Waste:

- ↓ 96.5% reduction vs. baseline (FY01)
- ↓ 57% reduction vs. previous year

Landfill Waste Per Auto:

- ↓ 96.8% reduction vs. baseline (FY01)
- ↓ 48% reduction vs. previous year

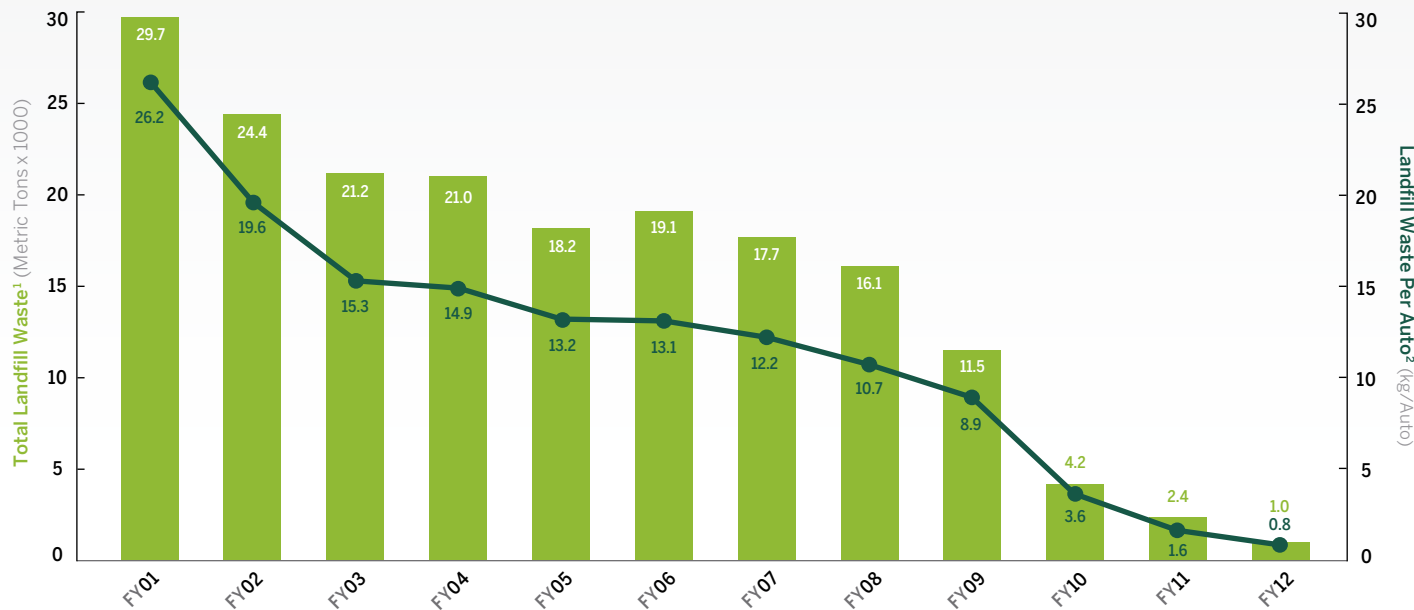

<sup>1</sup> Total landfill waste includes all North American manufacturing operations.

<sup>2</sup> Landfill waste per auto includes all auto-related manufacturing operations; it does not include power equipment production operations.

## Water Use

Honda's North American plants continued to strive to improve water efficiency; however, dramatically lower production levels had a severe impact on the water intensity (per-unit consumption of water) in FY12.

### Water Use

#### WATER USE BY SOURCE

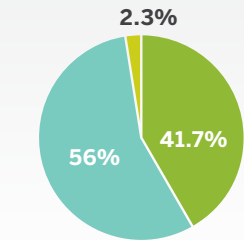

- **56%** Purchased from Water and Local Utilities
- **41.7%** Direct Ground Water Withdrawal
- **2.3%** Rainwater Capture and Reuse

#### WATER USE IN NORTH AMERICAN MANUFACTURING FACILITIES

##### FY12 RESULTS

##### Total Water Use:

- ↑ **37.8% increase vs. baseline (FY01)**
- ↓ **2.7% reduction vs. previous year**

##### Water Use Per Auto:

- ↑ **21.4% increase vs. baseline (FY01)**
- ↑ **3.7% increase vs. previous year**

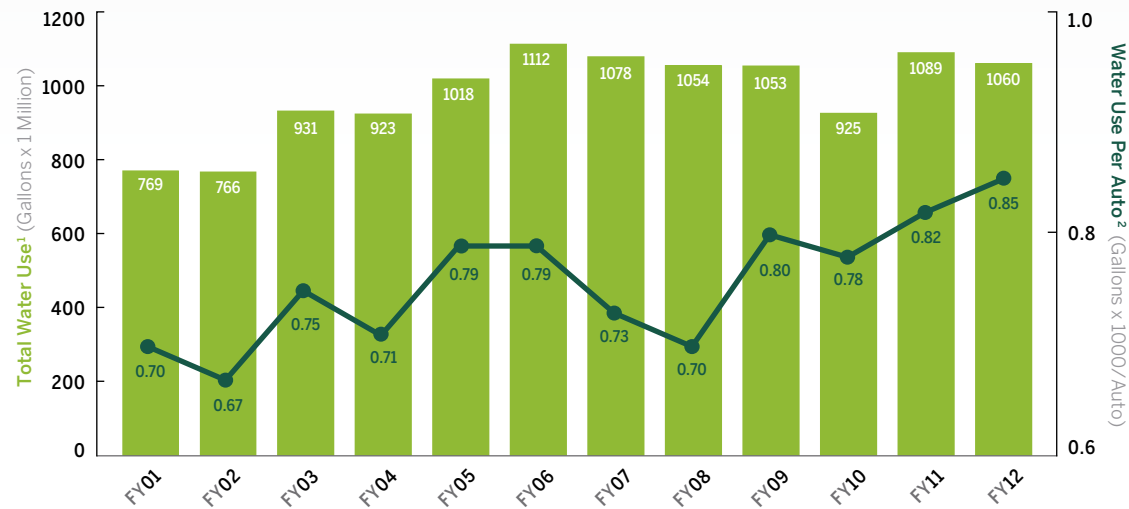

<sup>1</sup> Total water use includes all North American manufacturing operations.

<sup>2</sup> Water use per unit of automobile production includes all automobile, automobile engine, and automobile transmission production in North America; it does not include power equipment production operations.



## Water Use cont'd

### Wastewater Management

Domestic wastewater is generated from the use of restrooms, water fountains, cafeteria operations, and air conditioning related to associate (employee) comfort. Industrial wastewater is generated primarily from painting, surface treatment, and machining operations. Plants that generate industrial wastewater pre-treat the water on-site to reduce the contaminants to below regulated levels before the water is discharged into local municipal wastewater treatment plants. The pre-treated wastewater must meet regulatory requirements established

at municipal, state, and federal levels. Less than 1% of wastewater is trucked off-site for treatment.

Manufacturing plants also discharge wastewater directly to local waterways. Several plants also have National Pollutant Discharge Elimination System (NPDES) permits, which allow the discharge of storm water associated with industrial activation, including cooling tower blow down and air conditioning condensate. The NPDES permits set contaminant limits and mandate periodic sampling and reporting.

## Wastewater Discharge and Disposal

### WASTEWATER DISCHARGED FROM N.A. MANUFACTURING FACILITIES

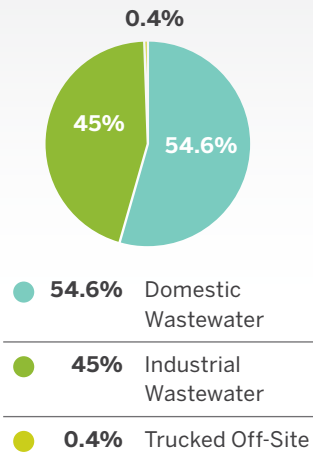

### INDUSTRIAL WASTEWATER DISCHARGED FROM N.A. MANUFACTURING FACILITIES

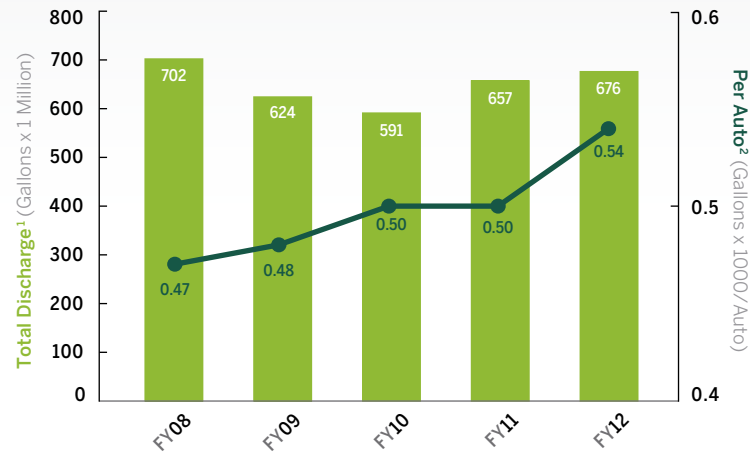

#### FY12 RESULTS

##### Total Discharge:

⬆️ **2.9% increase**  
vs. previous year

##### Per Auto:

⬆️ **8.2% increase**  
vs. previous year

<sup>1</sup> Total wastewater discharged includes all North American manufacturing operations.

<sup>2</sup> Total wastewater discharged per unit of automobile production includes all auto-related manufacturing operations in North America; it does not include power equipment production operations.

## Air Emissions

Honda plants release various "criteria" air contaminants, including volatile organic compounds (VOCs), particulate matter (PM), oxides of nitrogen (NO<sub>x</sub>), oxides of sulfur (SO<sub>x</sub>), and carbon monoxide (CO). VOC emissions typically come from painting operations. PM emissions usually result from metal casting and finishing processes, and from painting operations. NO<sub>x</sub> and CO emissions typically result from the combustion of natural gas and other fuels for heating and process needs, and from the use of engine and full-vehicle testing dynamometers.

Air emissions are permitted and controlled in accordance with applicable laws and regulations. Each plant routinely monitors, tracks, and reports emissions levels to regulatory agencies in accordance with federal, provincial, and state requirements. Honda factories are routinely inspected for compliance with legal requirements.

### VOC Emissions from Auto Body Painting

Auto painting operations are the primary source of volatile organic compound (VOC) emissions released from Honda's North American manufacturing plants. It has always been Honda's policy to minimize the release of VOCs by adopting less-polluting painting processes whenever possible. VOC emissions from auto-body painting operations in FY12 were well below the company's target of 20 g/m<sup>2</sup>.

## Air Emissions

In calendar year 2011, Honda's North American manufacturing plants released approximately 3,262 U.S. tons of criteria air pollutants. Overall, 81.9% of the air contaminants released were VOCs.

### MAKEUP OF AIR EMISSIONS FOR N.A. MANUFACTURING FACILITIES

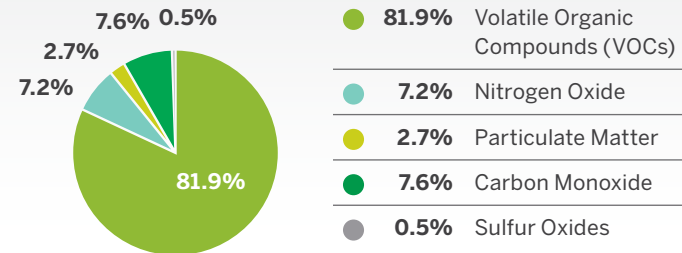

### VOC EMISSIONS<sup>1</sup> FROM AUTO BODY PAINTING IN NORTH AMERICA

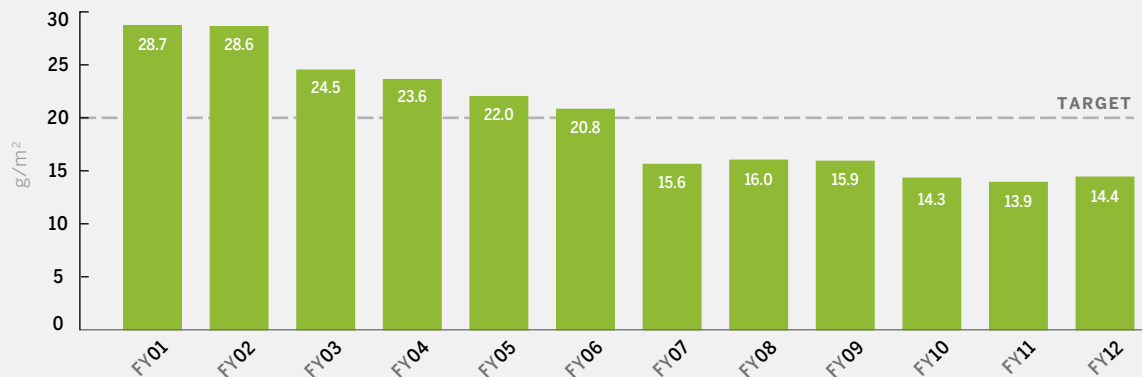

#### FY12 RESULTS

- ↓ **50% reduction vs. baseline (FY01)**
- ↑ **3.9% increase vs. previous year**

<sup>1</sup> Total VOC emissions data for fiscal years 2008, 2009, and 2010 have been recalculated based on corrected data for emissions from production at Honda's manufacturing operations in Mexico.

## Chemical Releases

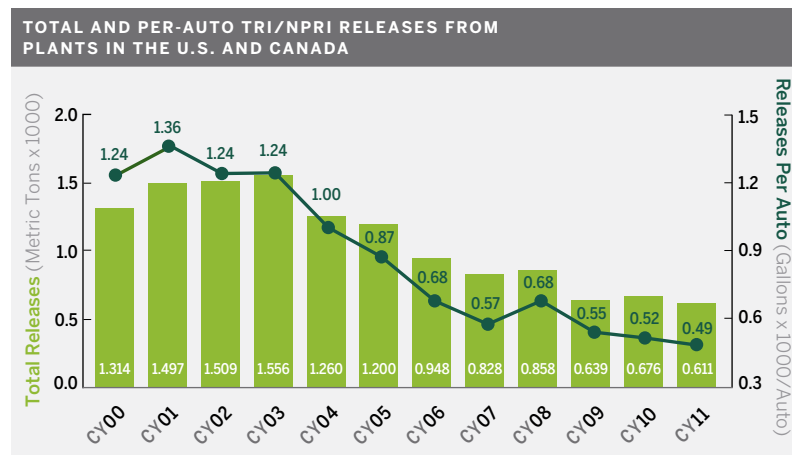

Honda has reduced its total Toxic Release Inventory (TRI) and National Pollutant Release Inventory (NPRI) emissions more than 53% since calendar year 2000, despite significant expansions in production capacity. Automobile-specific TRI/NPRI emissions per unit of production were reduced about 60% in the United States and Canada in the same period.

### Reducing Chemical Release—TRI/NPRI Reporting

Honda operations in the United States and Canada report total chemical releases annually in accordance with regulatory requirements. In the United States, TRI data are submitted to both state and federal environmental protection agencies. They are available for public review at [www.epa.gov](http://www.epa.gov). In Canada, NPRI data are submitted to Environment Canada and to the Ontario Ministry of the Environment, and are available for public review at <http://www.ec.gc.ca/inrp-npri/>.

### Ohio Tox-Minus Program

Ohio-based Honda of America Mfg. made a voluntary commitment to participate in the Ohio EPA's Tox-Minus Program. Honda's two automobile plants and one engine plant in Ohio committed to reduce total TRI emissions by 25% by the end of calendar year 2011 from a 2005 baseline. Honda of America Mfg. met this commitment,

reducing TRI emissions by 49.8% during the time period. The reduction was achieved primarily through the innovation of Line 2 painting operations at the Marysville Auto Plant and reformulation of some paint materials. In 2005, the Marysville Auto Plant replaced an older auto body painting line with a new painting line. The new line replaced solvent-borne primer/surfacer coating with waterborne, improved overall paint transfer efficiency, reducing paint usage, and added volatile organic compound emission control to the clearcoating operation, reducing overall TRI emissions from auto body painting.

### Accidental Spill and Release Prevention, Tracking, and Reporting

Prevention of environmental spills and releases is a key design consideration for all Honda manufacturing facilities. Exterior chemical and wastewater storage tanks and transfer systems are constructed with materials and designs that minimize the risks of leaks and spills. Most exterior tanks and piping systems have backup containment capabilities to recover any leaked or spilled material. Additionally, storage tanks are equipped with alarms to give advance warning of overfilling. Virtually all materials with the potential for release are handled within enclosed buildings. Learning from accidental releases is critical to preventing future occurrences. Therefore, Honda tracks all significant incidents. Major incidents undergo root-cause analysis, and Honda uses the information to improve operations.

### Underground Storage Tanks and Piping Systems

Honda is working to eliminate the use of underground storage tanks and underground piping systems for chemical and petroleum products. Since the construction of the automobile plant in Lincoln, Alabama, in 2001, all new North American plants have utilized only aboveground storage tanks and piping systems for chemicals and petroleum products.

Currently, Honda's Marysville and East Liberty, Anna Engine, and Canada auto plants operate 51 remaining underground storage tanks. In FY12, the Marysville auto plant replaced an existing waste oil underground storage tank and related piping system with an aboveground storage tank and piping.



---

## Energy Reduction Efforts in FY12

---

### Lighting Improvements through Technology and Management

Honda plants throughout North America continue to reduce lighting energy consumption through multiple initiatives:

- Minimized use of lighting during nonproduction times and between shifts, and on weekends and holidays.
- Eliminated high-bay lights no longer needed because of plant layout changes and increased use of task-specific lighting.
- Installed solar light tubes in the office area of Honda Power Equipment in Swepsonville, North Carolina.
- Used photovoltaic solar cells at the guardhouse for the Indiana auto plant.
- Replaced older T-12 fluorescent lighting technology with more efficient T-8 fluorescent and LED technology.
- Replaced high-bay metal halide fixtures with more efficient T-5 fluorescent fixtures at the East Liberty, Ohio auto plant.
- Replaced high-bay metal halide fixtures with more efficient LED fixtures at the Lincoln, Alabama auto and engine plant.
- Installed LED lighting for parking lot areas at the Anna, Ohio engine plant.
- Installed reduced wattage T-8 technology in areas with excessive lighting levels.

Two expansion projects at the Lincoln, Alabama auto plant, in the Plastics Injection Molding and Vehicle Quality operations areas, used energy-efficient LED lighting instead of traditional metal halide technology for interior high-bay lighting and for external lighting, avoiding about 40 metric tons of CO<sub>2</sub> emissions per year. A small, but elegant additional touch by the project team was the use of “glow-in-the-dark” technology in place of LEDs in the emergency exit signs, to capture an additional 196 kilograms of CO<sub>2</sub> emissions savings per year.



## Energy Reduction Efforts in FY12 cont'd

### HVAC

Honda of Canada Mfg., Inc. completed projects to reduce the amount of energy needed for the conditioning of air in its automobile body painting operations.

- Installed small exhaust fans in areas used to store and prepare paint to more efficiently manage airflow, allowing a larger airflow system to be shut down on weekends, saving 951 metric tons of CO<sub>2</sub> per year.

↓ **951 metric tons of CO<sub>2</sub>/year**

- An air-cascade project captures more than 95,000 cubic feet per minute of conditioned air from non-production areas for reuse in body painting booths, reducing the amount of energy used to condition air for the paint booths compared to bringing in untreated air from outside of the plant, resulting in a CO<sub>2</sub> savings of 1,840 metric tons per year.

↓ **1,840 metric tons of CO<sub>2</sub>/year**

The Weld department at the Marysville, Ohio auto plant has undergone many process and equipment layout changes since original construction of the plant in 1982. A project team gathered detailed temperature data throughout the department, verified the location and specifications of the current equipment, and conducted benchmarking activities with the newest Honda auto plant in North America, located in nearby Greensburg, Indiana. The team was able to rebalance air flows within the department, shutting down two air handlers and four exhaust fans. These changes will reduce CO<sub>2</sub> emissions by more than 4,200 metric tons per year.

↓ **4,200 metric tons of CO<sub>2</sub>/year**

### In-Process

#### Inventory Control

At the Anna, Ohio engine plant, a project was implemented to modify furnaces that hold molten aluminum prior to use in aluminum die casting. The refractory used to line the holding tanks was modified to reduce the volume of molten metal in storage by approximately 40%. This change reduced the electricity required to maintain temperature in the holding furnaces, resulting in an annual CO<sub>2</sub> savings of approximately 50 metric tons.

↓ **50 metric tons of CO<sub>2</sub>/year**

#### Compressed Air Usage Reduction

The Anna engine plant continued to reduce the amount of compressed air needed to cool dies in low pressure die casting. Retooling of dies for new model production allowed replacement of compressed air with water for cooling dies to solidify the molten aluminum into automobile parts, eliminating 265 metric tons of CO<sub>2</sub> per year.

↓ **265 metric tons of CO<sub>2</sub>/year**

### Paint Renovation

The East Liberty, Ohio auto plant continued renovation of body painting operations. The renovation project began in 2009 and will continue through 2013, and includes the replacement of painting booths, robots, and control panels while also implementing new painting control technologies. Renovation of the basecoat and clearcoat coating operations has improved energy efficiency by reducing the size of paint booths by 43%, eliminating about half of the painting robots and upgrading paint curing ovens. CO<sub>2</sub> emissions have been reduced by about 3,800 metric tons annually.

↓ **3,800 metric tons of CO<sub>2</sub>/year**



---

## Waste Reduction Initiatives in FY12

---

### Reducing Steel Scrap

None of Honda's offal (steel scrap) goes to landfills. All of it is recycled, with some transported to the Anna, Ohio engine plant for use in the manufacture of drivetrain components. The balance is shipped to steel recycling facilities. However, minimizing the generation of steel scrap reduces the environmental impact of material recycling and moves the generation of scrap steel up Honda's waste hierarchy closer to zero waste. An initiative begun in FY09 to minimize the size of steel sheets (blanks) used to form body parts has continued and through FY12 has reduced waste by more than 10,500 metric tons. As each new model is launched, the principles of this activity are applied to further reduce steel scrap. Also in FY12, Honda began to expand this activity to parts suppliers for additional waste reduction.

### Reduced Waste Cafeteria Operations

Honda's Anna Engine Plant continued to expand the use of washable dishware in its cafeterias. The plant eliminated one cafeteria and renovated a second cafeteria to incorporate the use of washable dishware.



Life Cycle Assessment

# Sales and Service

## Overview

The sales and service of Honda and Acura products requires the movement of both finished products and service parts by trucks and trains traveling millions of miles each year, resulting in the emissions of CO<sub>2</sub> and other byproducts of fuel consumption, as well as waste associated with the packaging of products and parts for shipment.

## Focus

Reducing waste and CO<sub>2</sub> emissions associated with the packaging and distribution of service parts for Honda and Acura automobile, powersports and power equipment products continues to be the focus of the company's U.S. distribution, service parts, and packaging departments.

## CO<sub>2</sub> Emissions from the Transportation of Service Parts in the United States

Through a series of initiatives, including the use of more fuel-efficient trucks, shifts in the mode of transport, more efficient packing of tractor trailers, and the reengineering of drive routes, Honda has endeavored to reduce CO<sub>2</sub> emissions associated with the distribution of service parts from its supplier factories to its warehouses and, ultimately, to dealerships.

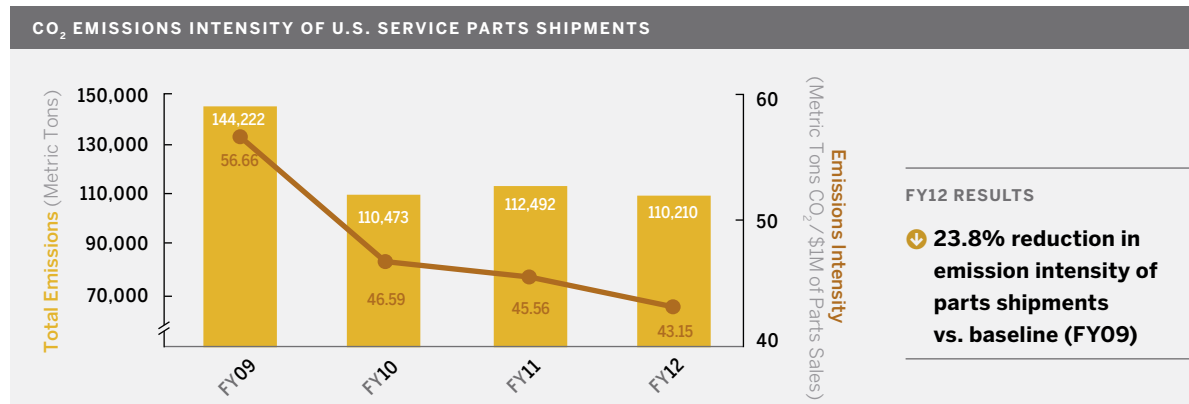

**FY12 RESULTS**

↓ **23.8% reduction in emission intensity of parts shipments vs. baseline (FY09)**

## CO<sub>2</sub> Emissions Reductions for Service Parts Shipments in the United States in FY12

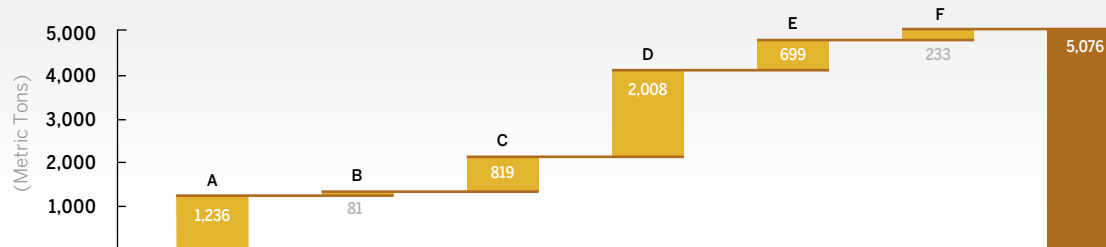

**FY12 RESULTS**

↓ **5,076 total reduction in metric tons**



**A. Modal shift from truck to rail**

Through a partnership with Union Pacific Distribution Services, Honda has undertaken a shift from trucks to rail for the transportation of parts between Honda's service parts suppliers in Mexico and its U.S. parts distribution centers.



**B. Conversion to LNG/CNG trucks**

Honda is piloting a program to replace diesel-powered trucks with trucks using liquid (LNG) and compressed (CNG) natural gas. LNG/CNG-powered trucks emit 25% less CO<sub>2</sub> emissions than their diesel counterparts. LNG/CNG units traveled more than 120,000 miles in FY12.



**C. Increased parts packing efficiency**

Honda aims to maximize the volume of parts on each transfer truck by tracking the usage of the shipping cubes used to transport parts. "Cube efficiency" has been increased 28% over the past four years.



**D. More fuel-efficient trucks**

In FY12, American Honda deployed 134 trucks utilizing more fuel-efficient engines, improved aerodynamic design, low rolling resistance tires, and idle reduction technology.



**E. Route tracker technology**

In FY10, Honda initiated the use of Route Tracker technology to monitor key performance attributes, e.g., idle time and hard braking, which, in conjunction with driver incentives for more fuel-efficient driving, is helping to improve the efficient operation of trucks.



**F. Reengineered delivery routes**

Through the engineering of truck routes, Honda reduced truck travel by more than 71,000 miles in FY12.



## Zero Waste to Landfill Parts Distribution Centers

The goal of Honda's parts distribution facilities in the U.S. is to achieve zero waste to landfill. This effort to reduce, reuse, and recycle waste material from these distribution centers resulted in 11,558 pounds of packaging and shipping material, or 92% of all waste material, being diverted from landfill in FY12.

The company's Chino, California operation is the first of these facilities to achieve zero waste to landfill.

RECYCLING ACTIVITY AT U.S. SERVICE PARTS DISTRIBUTION CENTERS

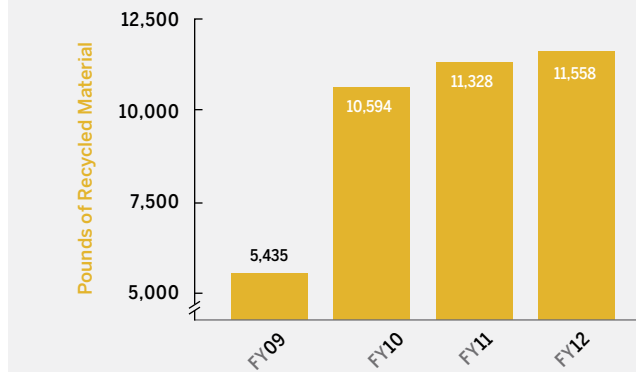

### CHINO, CALIFORNIA PARTS CENTER ACHIEVES ZERO WASTE TO LANDFILL

American Honda's facility in Chino, California in FY12 implemented a program to eliminate waste from the packaging and distribution of service parts. Associates working in partnership with American Honda's waste solutions partner, Link International, set up a program to eliminate waste to landfill and to document and validate its performance on a monthly basis. Their process is now being shared with American Honda's other parts distribution facilities in the U.S. for future application.

The facility also serves as the home to American Honda's first Hybrid Battery Consolidation Center, opened in October 2011. The facility consolidates all hybrid batteries from dealerships as well as natural gas tanks from CNG-powered Civics.

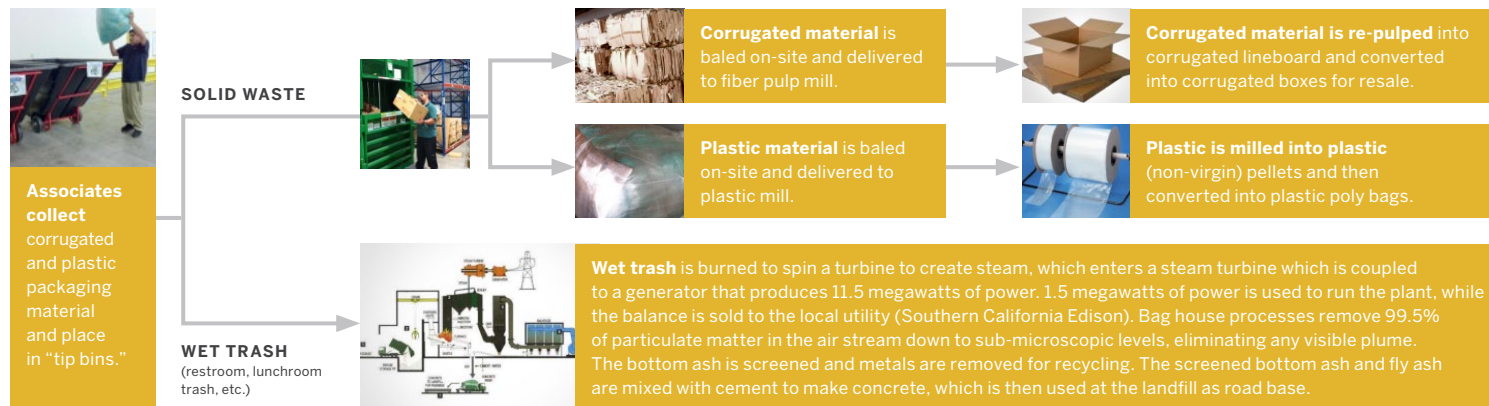



## Packaging Reduction and Recycling Improvements

### Packaging Reductions

Honda's U.S. service parts packaging group has worked to reduce its environmental footprint by changing package designs, and increasing the use of returnable packing and shipping material. Through a focused effort between Honda's service parts suppliers and American Honda, 109 part numbers were targeted for packaging improvements in FY12.

#### PACKAGING REDUCTION INITIATIVES IN FY12

Packaging changes and material reductions	69,000 pounds of corrugated material
	11,000 pounds of wood

### Pallet Recycling

Honda's North American Service Parts Packaging Operations has worked continuously to expand its pallet recycling program and has repaired and recycled nearly 78 million pounds of wood since the program's inception in 2002, including 175,00 pallets (9.6 million pounds of wood) diverted from landfills in FY12.

#### PALLET RECYCLING

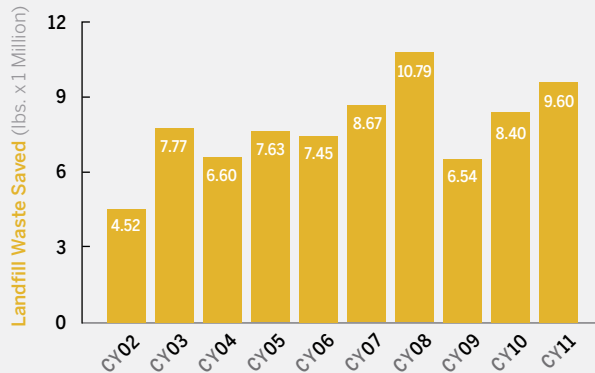

### Service Parts Recycling

In partnership with its U.S. Honda and Acura automobile dealers, American Honda has developed a continually expanding service parts recycling program. A variety of service parts are recycled, including batteries, wheels, and other parts containing precious metals, glass, copper, and plastic.

#### BATTERY RECYCLING IN THE U.S.

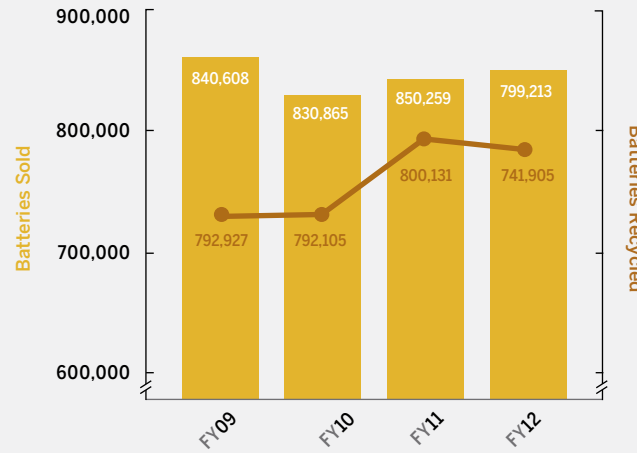

## Sales and Distribution of Honda Products

Honda is committed to delivering finished products using the most efficient transportation methods, which help to minimize the environmental impact.

### Modal Efficiency

The vast majority of Honda and Acura automobiles are moved by train. In FY12, 79.5% of all automobiles manufactured in the U.S. or arriving at U.S. ports were transported by train.

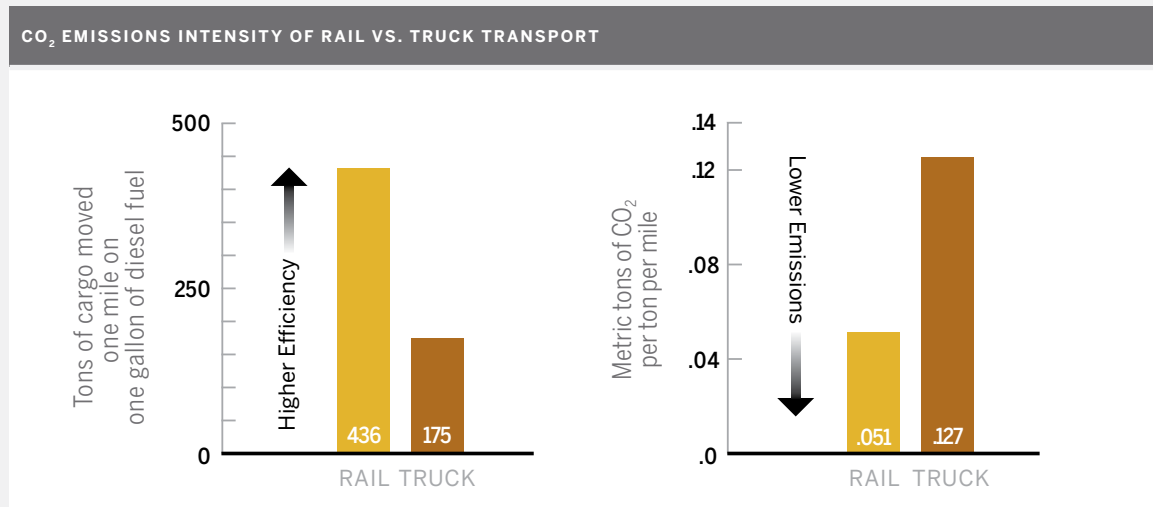

#### More Fuel-Efficient Trucks

95% of American Honda's U.S. fleet of trucks are EPA SmartWay Transport certified with a goal of 100% by the end of FY13. In addition, for FY12, trucks with electric power take off are being added to reduce fuel consumption and CO<sub>2</sub> emissions.

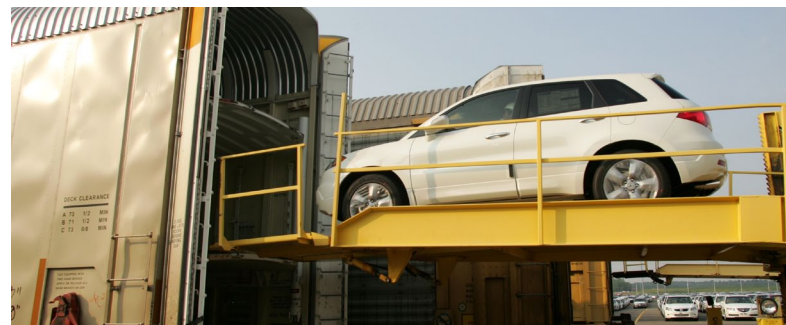

#### Honda Employs Auto-Max Railcars

These tri-level railcars are able to carry more vehicles in a single load to reduce energy consumption and emissions from the transport of finished products. 37% of vehicles moved by rail in FY12 were transported on Auto-Max cars.



## Honda and Acura “Green Dealer” Program



In FY12, American Honda launched its “green dealer” program for more than 1,300 independently owned and operated Honda and Acura automobile dealers in the U.S.

The Honda Environmental Leadership Award and Acura Environmental Leadership Award are given to dealers who quantifiably reduce their environmental impact, beginning with a minimum 10% reduction in total energy use at their dealerships. Ten dealers have already received the award, 18 more have applied to be in the program, and more than 200 dealers have independently developed initiatives to reduce their environmental impact.

### The program offers three achievement levels:

LEVEL	REQUIREMENT
<b>Silver</b>	10% reduction in total energy use Develop and implement a comprehensive recycling program Develop a water use reduction plan
<b>Gold</b>	Silver-level requirements (as above) Continuous improvements in reduction and conservation goals above the Silver level
<b>Platinum</b>	LEED certification of facility by U.S. Green Building Council

The company uses a third-party evaluator to conduct environmental audits of participating dealers and recommend strategies for reducing their energy use.

Dealers who have already earned the Honda or Acura Environmental Leadership Award are:

HONDA — PLATINUM LEVEL	
<b>Headquarter Honda</b>	Clermont, FL
HONDA — SILVER LEVEL	
<b>Rock Honda</b>	Fontana, CA
<b>Joe Morgan Honda</b>	Monroe, OH
<b>Rossi Honda</b>	Vineland, NJ
<b>Honda of Burleson</b>	Burleson, TX
<b>Diamond Honda</b>	City of Industry, CA
<b>Voss Honda</b>	Tipp City, OH
ACURA — SILVER LEVEL	
<b>McDaniels Acura</b>	Columbia, SC
<b>Norm Reeves Acura of Mission Viejo</b>	Mission Viejo, CA
<b>Acura of Peabody</b>	Peabody, MA

In addition to the dealers who received the Environmental Leadership Award for their quantifiable energy reductions, a number of Honda and Acura dealers have independently taken steps to address their environmental impact by:

- replacing lighting with low-energy lamps;
- installing motion sensors that turn lights off when not in use;
- replacing older air conditioning and heating systems with more energy-efficient equipment;
- installing solar panels;
- adding rainwater collection systems, and planting native vegetation to reduce irrigation water use.



Life Cycle Assessment

# In-Use

## Overview

Generally, the largest environmental impacts of Honda products come from the combustion of fuel during customer use, primarily greenhouse gas and smog-forming exhaust emissions. In the case of automobiles and motorcycles, the environmental impact is measured on a per-distance-traveled, and in the case of power products and marine, they are measured on a per-hour-used basis.

## Focus

Honda is strongly focused on advancements to the fuel efficiency of its vehicles as the most effective means of reducing greenhouse gas emissions that contribute to global warming and reducing the consumption of non-renewable fossil fuels.

## Automobiles

### Fuel Efficiency

Estimates made using the Honda Life Cycle Assessment (LCA) Data System indicate that approximately 86% of CO<sub>2</sub> emissions from its automobiles occur during customer use.

#### SOURCES OF AUTOMOBILE LIFE-CYCLE GHG EMISSIONS<sup>1</sup>

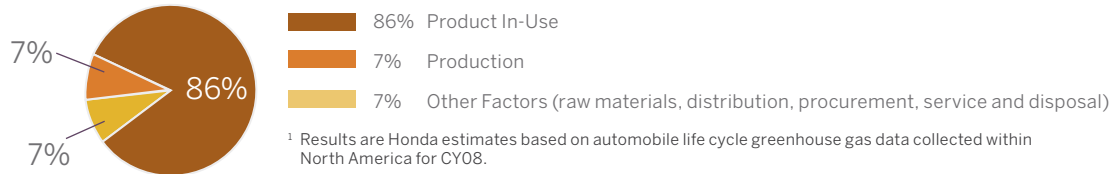

### Corporate Average Fuel Economy (CAFE)

Corporate Average Fuel Economy (CAFE) and Corporate Average Fuel Consumption (CAFC), as determined the U.S. Department of Transportation and Transport Canada, respectively, are regulatory constructs that use a less energy-intensive measure of vehicle fuel economy compared to the U.S. EPA (window label) fuel economy measure for new vehicles (see next page). CAFE also incorporates numerous other factors, including credits for alternative and flex fuel vehicles and is therefore less reflective of real-world fuel economy performance.

#### U.S. CAR AND LIGHT TRUCK FUEL ECONOMY (CAFE)<sup>1</sup>

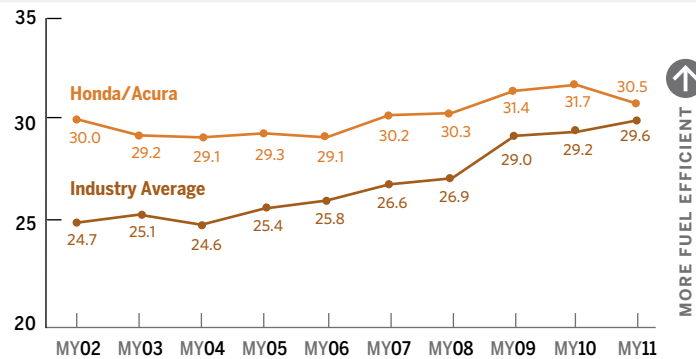

<sup>1</sup> The U.S. Environmental Protection Agency (EPA) calculates "fuel economy" by the amount of miles traveled per gallon of gasoline for cars and light trucks, and calculates a sales-weighted Corporate Average Fuel Economy (CAFE) number for both passenger cars and light trucks. The combined values shown here are for comparison purposes only.

<sup>2</sup> Industry average for model year 2011 is Honda's estimate based on each manufacturer's mid-model-year CAFE report as submitted to the NHTSA.

#### CANADIAN CAR AND LIGHT TRUCK FUEL CONSUMPTION (CAFC)<sup>1</sup>

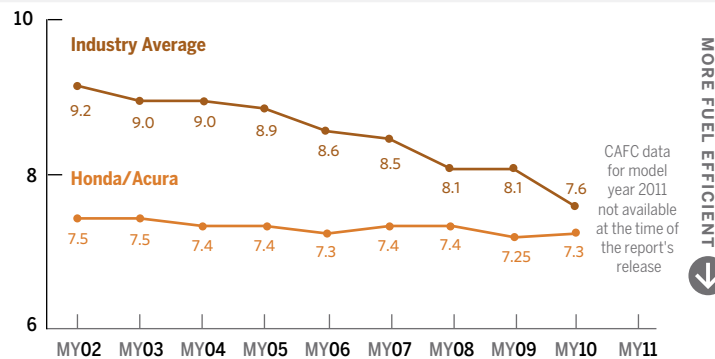

<sup>1</sup> Transport Canada calculates "fuel consumption" by the amount of fuel consumed per kilometer traveled. Transport Canada does not issue a combined number for cars and light trucks. The combined numbers reported above were calculated by Honda, using Transport Canada car and light truck CAFC results, along with available calendar year sales data.

<sup>2</sup> Industry average for model year 2011 is Honda's estimate based on each manufacturer's mid-model-year CAFC report as submitted to Transport Canada.



The Automobile segment includes Honda and Acura brand passenger cars, minivans, sport-utility vehicles, and pickup trucks.

**Automobiles** cont'd

**U.S. EPA Fuel Economy**

The U.S. EPA annually issues a report on light-duty vehicle fleet fuel economy and CO<sub>2</sub> emissions that uses values that are adjusted to better reflect the real-world experience of customers. The EPA released its most recent report on fuel economy trends in the U.S. in March 2012.

**U.S. CO<sub>2</sub> – ADJUSTED FLEETWIDE FUEL ECONOMY<sup>1</sup>**

**MY11 RESULTS**

- ⬆️ **3.2% improvement vs. previous year**
- ⬆️ **12.7% better than industry average**

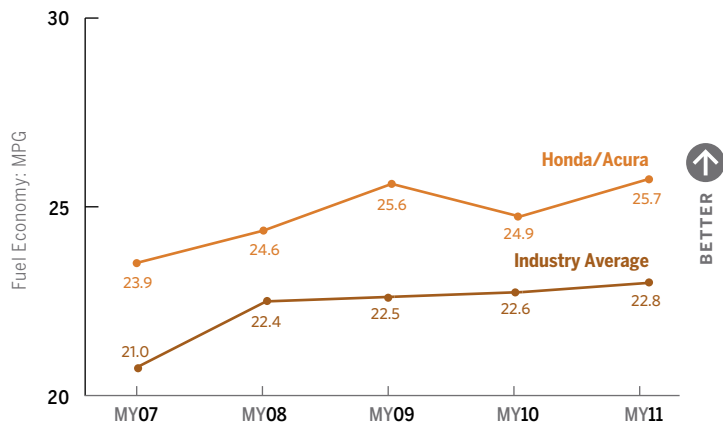

**U.S. FLEETWIDE ADJUSTED COMPOSITE CO<sub>2</sub> EMISSIONS<sup>1</sup>**

**MY11 RESULTS**

- ⬇️ **3.4% reduction vs. previous year**
- ⬇️ **13.3% better than industry average**

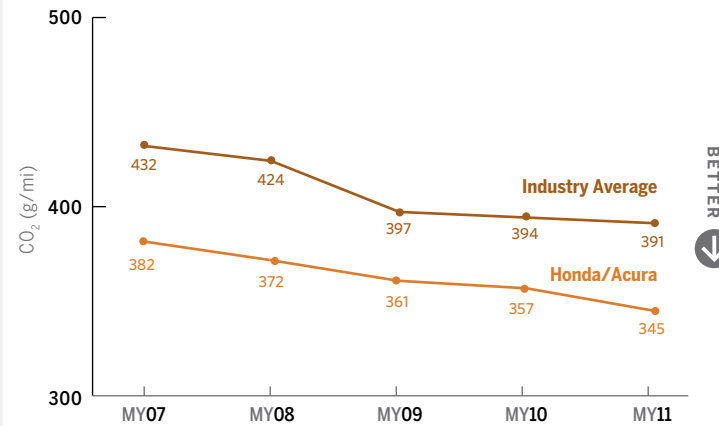

<sup>1</sup> Source: U.S. Environmental Protection Agency: Light-Duty Automotive Technology, Carbon Dioxide Emissions, and Fuel Economy Trends: 1975 through 2011, published March 2012



## Automobiles cont'd

### Tailpipe Emissions

Non-methane organic gasses (NMOG) tailpipe emissions are a pre-cursor to smog. The California Air Resources Board (CARB) controls NMOG under the Low-Emissions Vehicle (1996 and later) and Low-Emissions Vehicle II (2004 and later) emissions regulations. Honda has been very aggressive in reducing its fleet emissions below the LEV and LEV II standards. Over the past 11 years, Honda has reduced its fleet NMOG emissions by more than half. Honda opted into the LEV II regulations three years earlier than required.

#### HONDA FLEET AVERAGE NMOG VS. ARB FLEET REQUIREMENT (CALIFORNIA)

##### MY11 RESULTS

- ➔ No change from previous year
- ➔ 55% reduction from baseline (MY00)

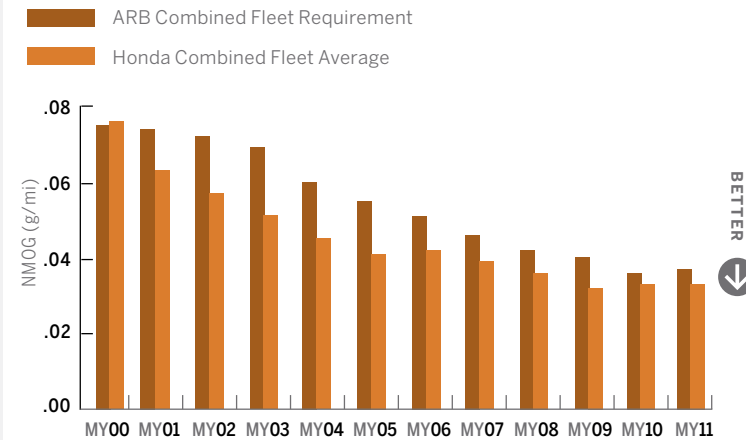

Source: NMOG reports submitted to the California Air Resources Board by Honda.



## Powersports Products

### Fuel Efficiency

Since 2000, Honda has achieved a 15.0% improvement in the fleet-average fuel economy of motorcycles sold in North America, primarily through the expanded use of programmable electronic fuel injection (PGM-FI) and changes in its model mix to smaller, more fuel-efficient products. The dramatic improvement in the MY11 result is mainly a reflection of production adjustments associated with the weakened economy.

#### FLEET AVERAGE FUEL ECONOMY IMPROVEMENT FOR MOTORCYCLES SOLD IN NORTH AMERICA<sup>1</sup>

##### MY11 RESULTS

- ↑ **23.7% improvement from previous year (MY10)**
- ↑ **41% improvement from baseline (MY00)**

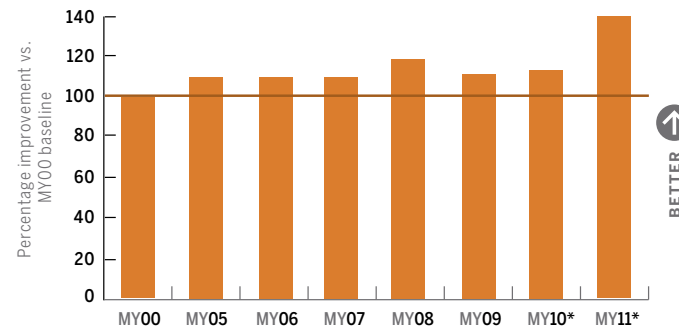

<sup>1</sup> Honda calculation using U.S. EPA exhaust emissions data.

FY00–09 were based on actual sales, and the 2010 and later data are based on production volumes. Some MY production is sold in later years (ex: a 2009 MY motorcycle that is sold new in 2011) and was omitted by the earlier method.



The Powersports Products segment includes Honda motorcycles for street, off-road, and dual-sport use; four-wheeled utility and recreational all-terrain vehicles (ATVs); and multipurpose utility vehicles (MUVs).

**Powersports Products cont'd**

**Tailpipe Emissions**

In model year 2011, Honda substantially outperformed both U.S. EPA and CARB Tier 2 requirements for hydrocarbon (HC), nitrogen oxides (NOx), and carbon monoxide (CO) exhaust emissions, in part through the use of 4-stroke engines and programmable electronic fuel-injection (PGM-FI) technology. In model year 2011, Honda also outperformed both EPA and CARB requirements for evaporative emissions and fuel permeation.

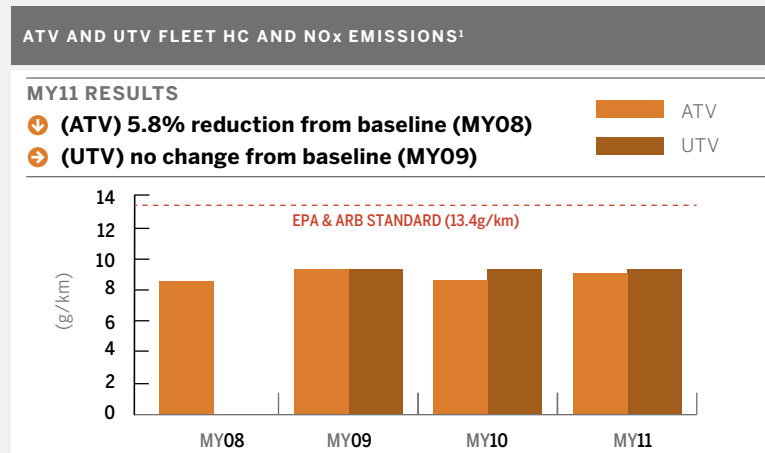
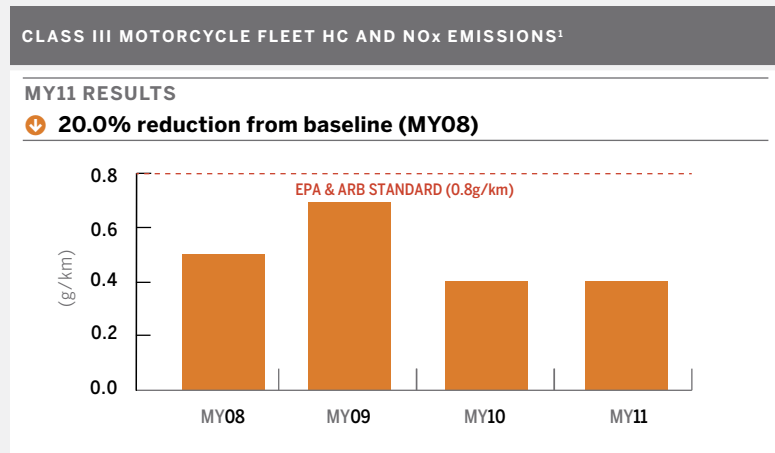
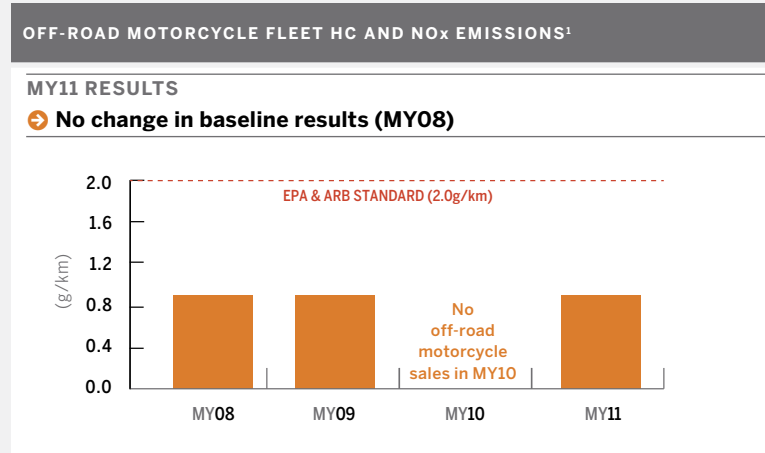
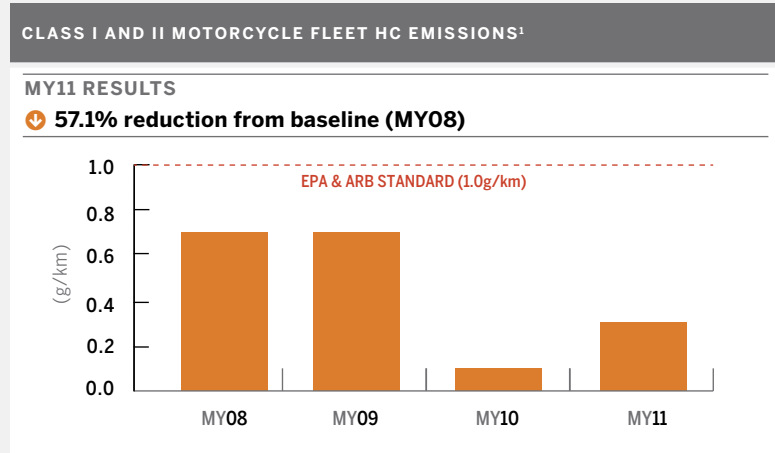

<sup>1</sup> Source: Honda internal test data



## Power Equipment Products

### Tailpipe Emissions

Honda achieves emissions substantially below U.S. EPA standards for 0–80cc engines due to its use of advanced, 4-stroke engine technology with multi-position carburetors. Although Honda 81–225cc engines are well below the 16.1 gram/kWh standard, a new standard of 10 grams/kWh goes into effect in MY12. Honda is building up credits to smooth its obligations as the standard’s efficiency increases dramatically. For MY11, Honda’s 226–1000cc engines are slightly above the new, more stringent 8 grams/kWh EPA standard (up from 12.1 grams/kWh in MY10). Honda is using previously earned credits to smooth out the transition in accordance with EPA regulatory flexibilities.

FLEET AVERAGE HC+NOX EMISSIONS OF HONDA ENGINES SOLD IN U.S. IN MY11

#### MY11 RESULTS

- ↓ (0-80cc) 52.4% below EPA standard
- ↑ (81-225cc) 10.0% above EPA standard
- ↑ (226-1000cc) 18.7% above EPA standard

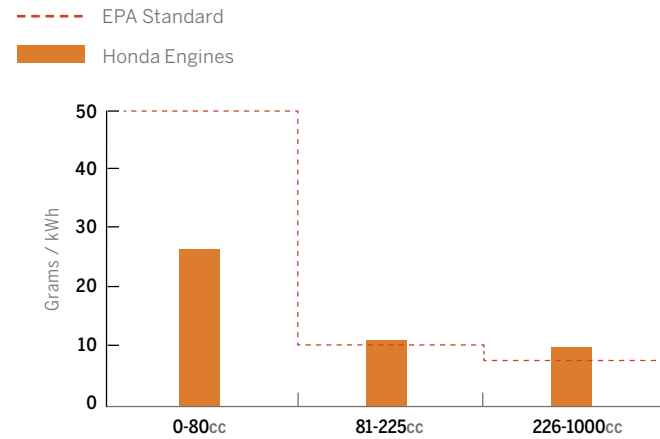

**The Power Equipment segment** consists of Honda lawnmowers, string trimmers, snowblowers, tillers, generators, and outboard marine engines, as well as general-purpose engines used in hundreds of applications for commercial, rental, and residential use.



Life Cycle Assessment

# End-of-Life

## Overview

The environmental impact of Honda products and service parts extends through their disposal or recycling at the end of their useful life. This includes service parts recovered by Honda and Acura dealerships during service repair and overstock parts in Honda warehouse facilities. While Honda does not directly participate in the disposal of its products, the company is working to make its products easier to recycle, while also taking a direct role in the reduction of waste associated with the disposal of Honda and Acura service parts.

## Focus

The first and most critical step is a product design that enables efficient dismantling for recycling and reduces the use of harmful substances

Additional efforts include projects aimed at increasing the quantity of recycled and remanufactured parts and materials, and more environmentally responsible means of disposing of unused parts and materials.

## Recycling of Electronic Waste (E-Waste), Warranty, and Overstock Service Parts

Implemented in 2006, Honda's program for recycling parts replaced under warranty utilizes the same procedures in place for regulated materials. In FY10, the program was expanded to include overstock service parts. Codes are assigned and used as filtering criteria to create lists that identify which parts will be destroyed and in what manner. Parts center personnel have been instructed to segregate items that require special handling and to deliver them to qualified regulated materials recycling vendors.

In FY09, American Honda's Service Parts Division implemented rigorous overstock disposal procedures for electronic waste (e-waste). Service parts are evaluated at the time of procurement to determine whether they qualify as e-waste, as OSHA hazards, or as "transportation dangerous" material regulated by the U.S. Department of Transportation. Nearly 5% of service parts have been coded for this special handling.

**FY12 Result:** More than 34 million pounds of recyclable material from electronic waste, warranty parts, and overstock service parts were diverted from landfills.

MATERIAL FROM E-WASTE, WARRANTY PARTS, AND OVERSTOCK PARTS DIVERTED FROM LANDFILL (THOUSANDS OF POUNDS)

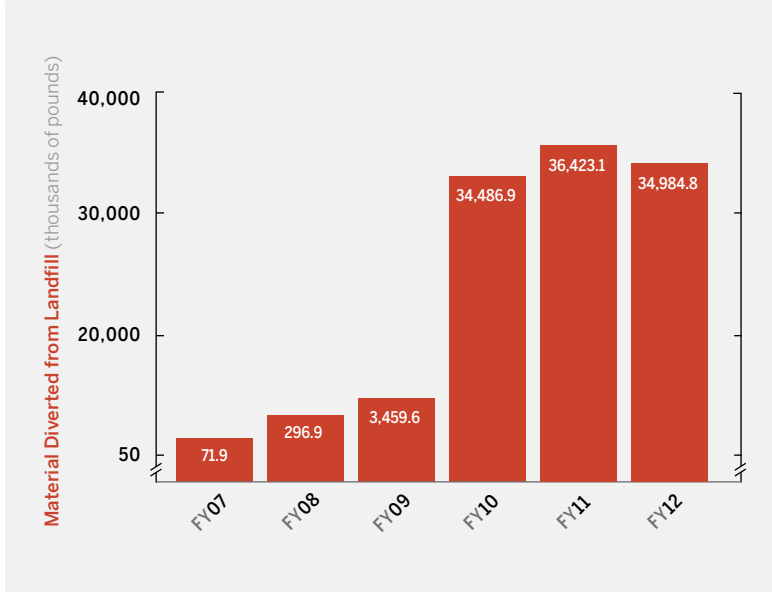

## Expansion of Honda's Remanufactured Parts Program

Remanufacturing parts at the end of their useful life removes them from the waste stream and reduces the amount of natural resources required to create new parts. Over the last two decades, Honda has greatly expanded the number of remanufactured parts it produces.

**FY12 Result:** Honda introduced 35 new remanufactured parts offerings.

REMANUFACTURED PARTS OFFERINGS IN THE UNITED STATES

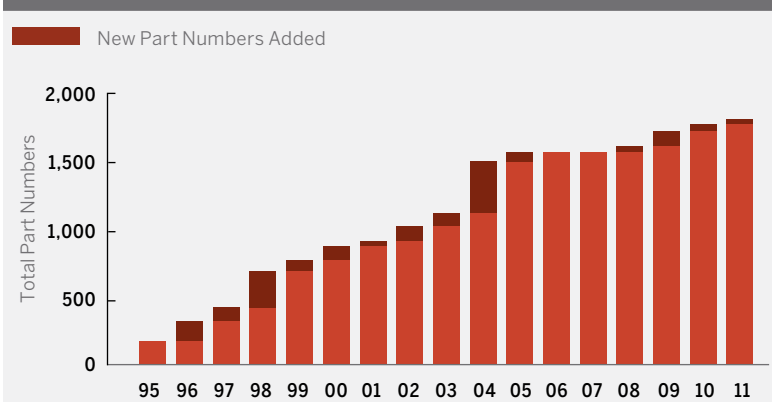

## Aluminum Wheels

In 2010, Honda launched a core charge program in the U.S. for aluminum wheels. The charge to the Honda or Acura dealer for each new wheel purchased from Honda is recoverable when the parts are returned.

**FY12 Result:** Honda collected more 42,000 wheels under the program.



## Post-Industrial Bumper (PIB) Recycling

Since 2000 Honda has been recycling post-industrial bumpers (PIBs) through third-party scrappers. In recent years, all PIBs coming out of five Honda plants in the U.S. and Canada are being reformulated and reused in Honda's own supply chain. Reformulated PIB pellets are turned into mud and splash guards.

**FY12 Result:** Honda recycled 1,015,015 pounds of post-industrial bumpers.

## Catalytic Converters

Catalytic converters, which are used for emissions control on all vehicles, contain platinum group metals (PGMs), which are extremely valuable. Recycling catalysts prevents these precious metals from ending up in landfills and reduces the need to mine PGMs. Honda began recycling catalytic converters in

December 2002. In FY12, Honda ceased collections through warranty replacements and instead implemented a core charge program, similar to the company's aluminum wheel program.

**FY12 Result:** Honda recycled over 300,000 units.

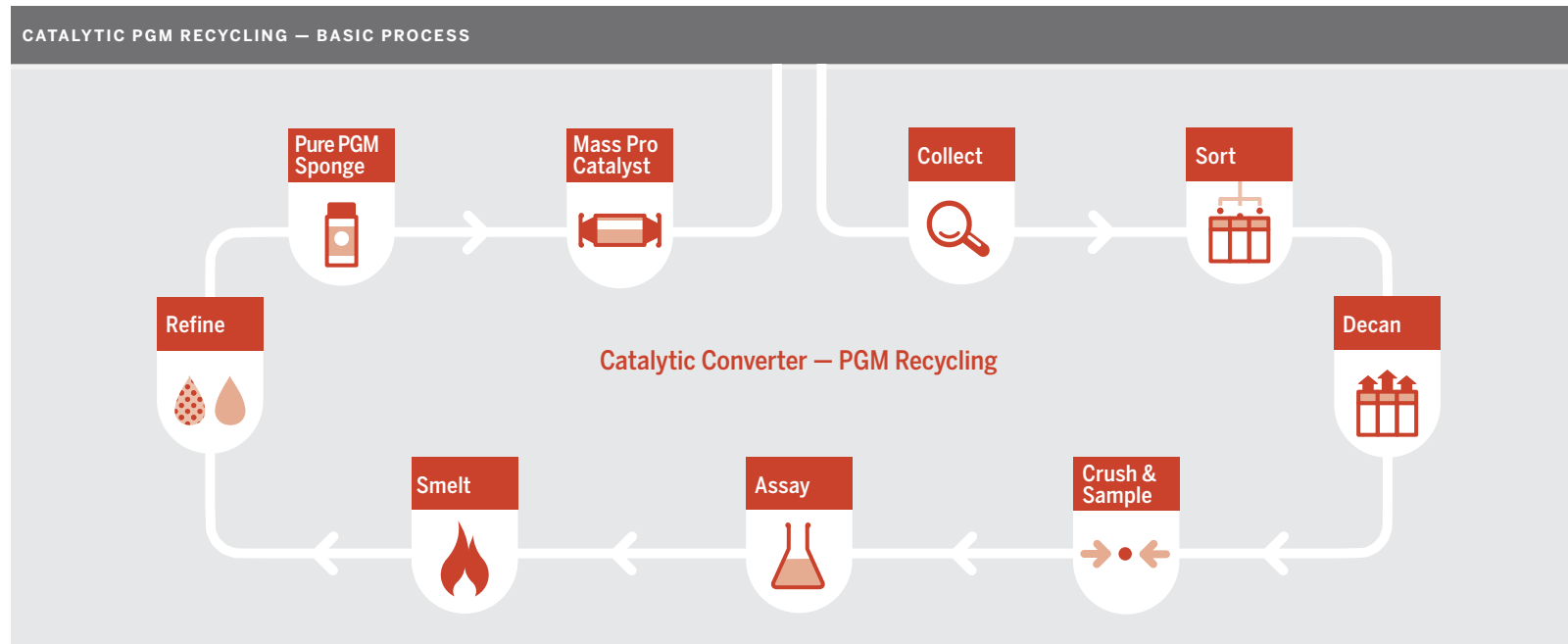



Life Cycle Assessment

# Administration

## Overview

Honda operates dozens of offices and warehouse facilities in North America to support R&D, Manufacturing, and Sales (distribution, marketing, service, and finance) operations in the region.

## Focus





Honda continually seeks out means of improving energy efficiency, water use, and eliminating waste from its administrative operations and has been a leader in the area of “green building” activities.



## Green Building Initiatives





Over the past two decades, Honda has been incorporating sustainable concepts into facility construction and operation, including the use of locally harvested and manufactured construction materials, cool roofs, dual-paned glass, high-recycled-content materials, and energy-efficient lighting. Honda now has 12 LEED-certified green buildings in North America, the most of any automaker operating in the region.

### Honda New, Existing, and Green Buildings in North America

NEW FACILITY		CERTIFICATION	DETAILS
	<b>Honda Financial Services</b> Southeast regional office	Gold Jun 2012	<p>82% of construction debris (47 tons) was diverted from landfill.</p> <p>Low mercury lamps in all light fixtures results in a 40% reduction in energy use for lighting.</p> <p>Forced-air hand dryers in restrooms reduce carbon footprint for this activity by 70%.</p> <p>90% of the facilities equipment meets Energy Star requirements.</p> <p>A “green cleaning” program reduced exposure to potentially harmful chemical compounds.</p>
EXISTING FACILITIES		CERTIFICATION	DETAILS
	<b>Honda Engineering America</b> Powertrain Division	Silver version 2.2 Jul 2011	<p>Low-flow toilets and urinals, energy-efficient lighting controls, and cool roof materials.</p> <p>Sustainable HVAC system features including enhanced equipment commissioning and refrigeration management.</p>
	<b>Honda Canada</b> Headquarters facility	Gold Jul 2011	<p>North-south building orientation, energy-efficient underfloor air-distribution system, heat-reflective white roof, and on-site storm water treatment using bioswales.</p> <p>Efficient water management system reduced potable water use by 44% (compared to previous facility).</p> <p>Use of locally sourced materials and 75% reuse or recycling of waste materials during construction phase.</p>
	<b>Honda Manufacturing of Indiana</b> Welcome Center	Certified Nov 2010	<p>The first LEED-certified building in Indiana’s Decatur County, the nearly 23,000-square-foot facility purchases 100% green power, utilizes wood certified by the Forest Stewardship Council, and provides designated parking for fuel-efficient vehicles.</p>

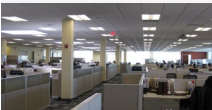

**Green Building Initiatives** cont'd

Honda New, Existing, and Green Buildings in North America			
EXISTING FACILITIES		CERTIFICATION	DETAILS
	<b>Honda R&amp;D Americas</b> Marine Engine Research Facility Grant-Valkaria, FL	Gold Mar 2010	5% of the two-acre site (adjacent to Intracoastal Waterway) converted to permanent conservation easement to help protect and preserve local wetlands and wildlife.  Reduced area covered by invasive/exotic species and replacing them with beneficial native vegetative species.
	<b>Honda Financial Services</b> Mid-Atlantic Facility Wilmington, DE	CI Gold Oct 2009	Ultra-low-flow lavatory and kitchen fixtures, high-efficiency fluorescent fixtures, and more than 90% of the office appliances are Energy Star rated.
	<b>American Honda</b> Northwest Regional Facility Gresham, OR	Gold 1999 Platinum Jun 2008	First new mixed-use industrial building in the United States to earn Gold certification.  First LEED Platinum-certified existing building in the automobile industry.  Rainwater harvesting, sensor-controlled lighting, passive heating system, and air conditioning system powered in part by roof mounted wind turbines.  48% more energy efficient than is required by Oregon's Energy Code.
	<b>Honda Aircraft Co.</b> World Headquarters Greensboro, NC	Gold Dec 2008	Uses steel wall panels with almost 35% recycled content, precision cut at the factory so that no waste was generated at the job site.  Low-flow toilets and urinals, infrared sensor faucets, and landscaping with native species and plants with low water needs.
	<b>American Honda</b> Midwest Consolidation Center Troy, OH	Gold Apr 2008	Reflective roof and energy-efficient lighting.  Second-floor mezzanine constructed from wood certified by the Forest Stewardship Council.



**Green Building Initiatives** cont'd

Honda New, Existing, and Green Buildings in North America			
EXISTING FACILITIES		CERTIFICATION	DETAILS
	<b>American Honda</b> Data Center Longmont, CO	Silver version 2.2 Apr 2008	First LEED Version 2.2 Silver-certified data center in the United States.
	<b>Honda R&amp;D Americas</b> Central Plant Raymond, OH	Gold Apr 2008	Rainwater-supplied low-flow toilets. Biodiesel-powered emergency generator. Ice chiller system that reduces peak energy demand from air conditioning by as much as half.
	<b>Honda R&amp;D Americas</b> Acura Design Studio Torrance, CA	Gold Mar 2008	Use of reclaimed water for toilets and irrigation. High-efficiency, displacement ventilation system.



## Energy, Emissions, and Waste Reduction Efforts within Honda Offices

Honda's regional parts distribution centers in Gresham, Oregon, and Davenport, Iowa, each have earned a U.S. EPA Energy Star award for energy-efficient operations. The facilities join two Honda automobile manufacturing plants in Ohio that recently received Energy Star recognition from the U.S. EPA.



Gresham, OR



Davenport, IA

Since receiving LEED-Platinum certification in 2008, Honda has completed several projects to further reduce energy consumption at the Gresham facility:

- more energy-efficient, sensor-activated warehouse lighting;
- zone lighting controls in the office area;
- a sub-metering electricity monitoring system to track energy consumption in the warehouse, office, training center, and mechanical equipment areas; and
- intelligent control of exterior lighting.

Since 2008, average yearly energy consumption at the facility has been reduced by 384,000 kilowatt-hours (kWh) for a total reduction in CO<sub>2</sub> emissions of approximately 150 metric tons over the past five years.

The Davenport, Iowa facility now utilizes:

- more energy-efficient T8 lamps in office areas and T5 lamps with motion sensors in the warehouse; and
- an exterior lighting controlled by a state-of-the-art digital lighting management system connected to the building automation system.

Since the completion of these upgrades, annual energy consumption at the 291,600-square-foot facility has been reduced by more than 922,000 kWh, or 31%, from previous levels, cutting yearly CO<sub>2</sub> emissions by an estimated 766 metric tons.



## Energy, Emissions, and Waste Reduction Efforts within Honda Offices cont'd

In FY12, Honda continued to reduce its energy consumption and improve the energy efficiency of its computing operations throughout North America.

### United States

#### Computer Virtualization and Replacement

The Information Systems division continued its efforts to consolidate, eliminate, and upgrade servers throughout North America and move to more energy efficient computing equipment.

Although the overall number of platforms at the North American Honda Data Center continued to grow, Honda managed to reduce its power utilization by approximately 33,594 KWh in FY12 versus the previous year, and CO<sub>2</sub> emissions by 23.1 metric tons over the same period. This savings was primarily due to two major consolidation and upgrade efforts:

- through a Lotus Notes upgrade effort, American Honda eliminated 63 older Domino servers located at 23 disparate locations and replaced them with 10 newer, more energy-efficient servers in a single data center, and
- the continued decommissioning and virtualization of older servers resulted in decreased energy requirements and CO<sub>2</sub> emissions.

Additionally, American Honda began refreshing personal computers throughout North America with newer, more efficient, Energy Star-rated technology. This eliminated an additional 9.3 Metric tons of carbon dioxide emissions and reduced power utilization by approximately 13,449 KWh in FY12.

#### Major U.S. Installation of Honda Solar Cells

American Honda also installed its largest commercial solar-cell demonstration project in the United States, at Honda Performance Development (HPD), Inc., in Santa Clarita, CA. The 100-kilowatt, 800-cell array of thin-film CIGS solar panels, manufactured by Honda Soltec Co., Ltd., are installed on the roof, carport, and loading dock canopy at the headquarters of HPD, where the company develops engine technology for numerous racing series including IZOD IndyCar, American Le Mans, and the Le Mans Series in Europe. The solar demonstration project is one of Honda's largest to date, providing power to several areas of the HPD research-and-development campus, while reducing energy loads and CO<sub>2</sub> emissions. Energy produced by the solar array is expected to reduce CO<sub>2</sub> emissions by approximately 64 metric tons annually.



Honda CIGS thin-film solar cells installed on the roof and carport of Honda Performance Development in Santa Clarita, California.

## Energy, Emissions, and Waste Reduction Efforts within Honda Offices cont'd

### Waste Reduction



Reduce, Reuse, and Recycle has become American Honda's working goal and mission as it relates to the possible creation of office and warehouse waste. American Honda's headquarters in Torrance, California, has earned recognition for the California Waste

Reduction Award Program for twelve consecutive years. In efforts to increase our commitment and contribution to the environment, AHM has recently become a WasteWise Partner (a national initiative of the U.S. EPA). During the past year, Honda has continued to emphasize the reduction and reuse of recyclable materials, through various communication media. The result was a continued overall decrease in the amount of materials being processed for recycling, as the chart below indicates.

REDUCTION OF RECYCLED OFFICE WASTE AT AMERICAN HONDA HEADQUARTERS (MILLIONS OF POUNDS, CY07-CY11)

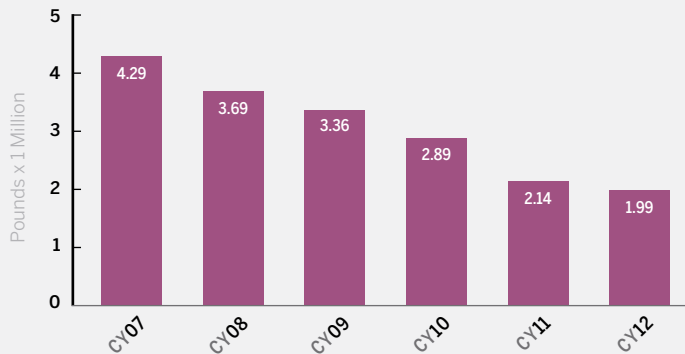

### Canada

#### Energy and CO<sub>2</sub> Emissions

Honda Canada's CO<sub>2</sub> emissions from electricity and natural gas consumption were reduced by 14%, compared to the previous fiscal year. This reduction was primarily due to the mild winter but also by improving room temperature control and lighting control practices. Likewise, water usage decreased by 36% compared to the previous year, again mostly attributed to the weather as well as more efficient use of water. There was, however, an increase of 16% in office paper usage as a result of Honda Canada Finance's move to the Honda Canada campus in October 2011.

#### Waste Reduction

Due to increased associate awareness, combined with the use of compostable dinnerware in the cafeteria, Honda Canada's recycling and composting diversion rate has increased to 83%, a 1% increase compared with the previous fiscal year.

In 2011, Honda Canada's "Green Office Task Force" launched with the objective of improving environmental performance in the office area. Some of the activities conducted are:

- raising associate awareness via "lunch and learn" sessions;
- promoting associate engagement and idea development; and
- holding a waste reduction competition.



## Associate Engagement

Honda encourages its associates to propose their own initiatives for reducing the company's environmental impact. The results can be seen in small and large ways throughout our operations. From algorithms for reducing energy use in manufacturing to double-sided printing, associates come together through annual competitions as well as informal groups to develop environmental initiatives.

### The Power of Water — Hydroelectric Power Generation



Micro-hydropower generation system at the Marysville, Ohio auto plant.

Associates at the Marysville Auto Plant in Ohio came up with a novel idea for reducing the company's electricity use — they decided to make their own.

The plant uses large compressors to produce more than 500 million standard cubic feet of compressed air each month for its assembly

line power tools, paint guns, and other processes. To keep them from overheating, water is circulated around the compressors, and is then pumped to the plant's five cooling towers. The water cools and drops back to a sump to be used again.

Retired Honda associate, Bill Thaman, realized that the water rushing down from the towers contained energy that could be recovered. Soon a team of associates came together to determine how.

The team selected an induction motor that could be used as a generator to create hydro power. Marc Fifolt performed the application engineering and led the installation of the turbine. Chris Cornelius and Andres Bonano took on the challenge of measuring the energy potential of the water. Chance Weber and Marc Iman built a dynamometer using spare automotive parts and scrap materials.

The end result: a nine horsepower hydro-power generator that generates about 50,000 kilowatt hours per year of electricity, and offsets CO<sub>2</sub> by 35,000 kilograms per year. A real-time web-based monitor tracks energy production.

50,000 kw/yr is a small amount compared to the overall energy use of the plant. But the technology associates created has the ability

to be adopted by other Honda plants, potentially multiplying the opportunities for energy reduction.

"Like a single drop, it's not that impressive," says Dirk Nordberg, an associate who oversaw the project. "But the whole ocean is made out of single drops of water."

### Reducing Waste — Everyone's Job

Among the many ways that Honda's associates come together to improve the company's environmental performance is through "NH Circles," an annual competition in which associates form teams and develop themes for improvement. Over the years NH or "New Honda" Circles have been responsible for identifying and reducing the company's environmental impact in big and small ways.













In 2011, Rosaline Gajeski, Nathan Ponce, Robert Goodwin, and Shawn McCullum — associates at Honda's Parts Center in Davenport, Iowa — identified an opportunity to reduce paper waste by creating more opportunities for recycling and making the process easier for all associates. Their research indicated that odd-sized paper waste — mostly the spools used from over 25 different packaging products such as packing tape and shipping labels — were not being fully recycled, as recycling bins could not always accommodate the odd-sized spools. There was also some uncertainty about whether the spools were recyclable, and recycle bins were not as prevalent as trash cans. They concluded that thousands of recyclable spools each month were ending up in landfill.

The team built its own prototype large-sized recycle bin to accommodate the spools, and based on the prototype, the company purchased similarly dimensioned bins to place throughout the parts center. The result was an annual reduction of nearly one ton of waste being sent to landfill.

## Environmental Community Activities

**OVERVIEW:** Honda is always looking for ways to make positive contributions to the communities where it does business, including helping preserve and protect the local environment.

**FOCUS:** Honda supports a broad range of community-based environmental education, preservation, and restoration efforts, in the form of corporate charitable giving, foundation giving, in-kind contributions, and company support of volunteer work by Honda associates who take an active role in their communities.

Environmental Education	
ORGANIZATION	FOCUS OF INVOLVEMENT
<b>Alabama PALS (People United Against A Littered State)</b> Montgomery Alabama USA <a href="http://www.alpals.org">www.alpals.org</a>	A partnership of state and local governments, civic groups, law enforcement, businesses, and industry aimed at educating and fighting against littering.  
<b>Appalachian Trail Conservancy</b> Harpers Ferry, West Virginia USA <a href="http://www.appalachiantrail.org">www.appalachiantrail.org</a>	Provides K-12 teachers with professional development training, using the Appalachian National Scenic Trail as a multidisciplinary, educational resource for ecology field studies, classroom curriculum, and service-learning. 
<b>Aquarium of the Pacific</b> Long Beach, California USA <a href="http://www.aquariumofpacific.org">www.aquariumofpacific.org</a>	Honda is a founding sponsor of this aquarium, whose mission is to instill in people of all ages a sense of wonder, respect, and stewardship for the Pacific Ocean, its inhabitants, and ecosystems.  
<b>Aullwood Audubon Center</b> Dayton, Ohio USA <a href="http://aullwood.center.audubon.org">http://aullwood.center.audubon.org</a>	Aullwood is an environmental education center in western Ohio whose goal is to promote the protection of birds and other wildlife, and the habitats on which they depend. Honda supports the center's educational outreach to elementary school children. 
<b>Auntie Litter</b> Birmingham, Alabama USA <a href="http://www.auntielitter.org">www.auntielitter.org</a>	Provides educational programs across the state to prevent littering. 
<b>Boy Scouts – Simon Kenton Council</b> Columbus, Ohio USA <a href="http://www.skbsa.org">www.skbsa.org</a>	Boy Scouts provides a program that builds character and provides a solid foundation to learn leadership skills and build character. Honda supports the Council's World Conservation summer program focused on recycling, wildlife conservation, water and soil conservation, and renewable energy.  
<b>Clean Air Champions</b> Ottawa, Ontario, Canada <a href="http://www.cleanairchampions.ca">www.cleanairchampions.ca</a>	Clean Air Champions' mission is to improve air quality and reduce climate change by working with high-performance athletes to educate and inspire Canadians, primarily youth, to adopt more-sustainable, healthier lifestyles. 
<b>Clean Fuels Ohio</b> Columbus, Ohio USA <a href="http://www.CleanFuelsOhio.org">www.CleanFuelsOhio.org</a>	This statewide non-profit organization is dedicated to promoting the use of cleaner domestic fuels and fuel-efficient vehicles. Honda supports the organization's educational activities and its Green Fleets Program.  













 FINANCIAL SUPPORT

 PRODUCT DONATION

 ASSOCIATE VOLUNTEER

 IN-KIND DONATION

## Environmental Community Activities

Environmental Education	
ORGANIZATION	FOCUS OF INVOLVEMENT
<b>Earth Day Indiana Festival</b> Indianapolis, Indiana USA <a href="http://www.earthdayindiana.org">www.earthdayindiana.org</a>	Educates people on the need and ways they can help protect the environment, conserve natural resources, and live a more sustainable lifestyle. 
<b>Earth Rangers</b> Woodbridge, Ontario, Canada <a href="http://www.cleanairchampions.ca">www.cleanairchampions.ca</a>	Dedicated to educating and inspiring children to Bring Back the Wild™ by protecting biodiversity and adopting sustainable behaviors. Hundreds of thousands of children are reached through interactive live animal shows in schools, at the Royal Ontario Museum, and at community events. 
<b>Franklin Park Conservatory &amp; Botanical Gardens</b> Columbus, Ohio USA <a href="http://www.fpconservatory.org">www.fpconservatory.org</a>	The conservatory promotes environmental appreciation and ecological awareness for visitors from throughout Ohio and around the world. Honda supports the conservatory's Children and Family Education Program. 
<b>Girl Scouts of Ohio's Heartland Council</b> Columbus, Ohio USA <a href="http://www.gsooh.org">www.gsooh.org</a>	Girl Scouts offers opportunities for girls ages 5-17 to develop leadership, teamwork, and consensus building. Honda supports the program, It's Your Planet – Love It! A Journey2Go Leadership Experience. Activities and events are designed to foster a better understanding of the importance of preserving the earth's natural resources.  
<b>The Greening of Detroit</b> Detroit, Michigan USA <a href="http://www.greeningofdetroit.org">www.greeningofdetroit.org</a>	The Greening's mission is to guide and inspire residents to create a greener Detroit through educational programs, environmental leadership, advocacy, and family gardens. It partners with federal, state, and local agencies, corporations, and foundations to assist neighborhood groups, churches, schools, and families to improve Detroit's ecosystem while teaching the advantages of good nutrition and growing one's own food.  
<b>Jane Goodall Institute of Canada</b> Toronto, Ontario, Canada <a href="http://www.janegoodall.ca">www.janegoodall.ca</a>	This institute supports wildlife research, education, and conservation and promotes informed and compassionate action to improve the environment. Objectives include increased Canadian awareness of and compassion for the plight of endangered animals, with a focus on chimpanzees. 
<b>Living Classrooms of the National Capital Region</b> Washington, D.C. USA <a href="http://www.livingclassroomsdc.org">www.livingclassroomsdc.org</a>	Offers programs to inspire young people to achieve their potential through hands-on education and job training using urban, natural, and maritime resources as "living classrooms."   
<b>The Kohala Center</b> Kamuela, Hawaii USA <a href="http://www.kohalacenter.org">www.kohalacenter.org</a>	Engages middle and high school students in field science research projects that promote environmental stewardship by addressing ecological issues occurring on the island. 







 FINANCIAL SUPPORT

 PRODUCT DONATION

 ASSOCIATE VOLUNTEER

 IN-KIND DONATION

## Environmental Community Activities

Environmental Education	
ORGANIZATION	FOCUS OF INVOLVEMENT
<p><b>Ohio Wildlife Center</b> Powell, Ohio USA <a href="http://www.ohiowildlifecenter.org">www.ohiowildlifecenter.org</a></p>	<p>This center is dedicated to fostering awareness and appreciation of Ohio's native wildlife through rehabilitation, education and wildlife health studies. Honda's grant helps support site upgrades as well as support for the Center's volunteer program.</p> <p> </p>
<p><b>Pee Dee Research and Education Center (Clemson University)</b> Pickens, South Carolina USA <a href="http://www.clemson.edu/public/rec/peedee">www.clemson.edu/public/rec/peedee</a></p>	<p>Partners with Clemson University to provide 100 acres of land to grow switchgrass to be used for biofuel research and development.</p> <p></p>
<p><b>Pinelands Protection Alliance</b> Southampton, New Jersey USA <a href="http://www.pinelandsalliance.org">www.pinelandsalliance.org</a></p>	<p>The Pinelands Preservation Alliance is the only nonprofit organization dedicated solely to the protection of New Jersey's Pinelands, supporting advocacy and educational programs designed to protect the Pinelands for future generations.</p> <p></p>
<p><b>Shelby Soil and Water Conservation District</b> Sidney, Ohio USA <a href="http://www.shelbyswcd.org">www.shelbyswcd.org</a></p>	<p>Honda supports the Envirothon, a team competition providing high school students an opportunity to gain a greater awareness of natural resources and environmental issues. It tests teams' knowledge of soils, forestry, wildlife, aquatic ecology, and current environmental issues.</p> <p></p>
<p><b>Wildlife and Industry Together (W.A.I.T.) South Carolina Wildlife Federation</b> Columbia, S.C. USA <a href="http://www.scwf.org/index.php/educationprograms/habitats/wait">http://www.scwf.org/index.php/educationprograms/habitats/wait</a></p>	<p>W.A.I.T.™ is designed to encourage corporate landowners to integrate wildlife habitat needs into corporate land management decisions. Honda associates have implemented many projects such as a butterfly garden, food plots, bird feeders and houses, and tree plantings.</p> <p> </p>













 FINANCIAL SUPPORT

 PRODUCT DONATION

 ASSOCIATE VOLUNTEER

 IN-KIND DONATION

## Environmental Community Activities

Environmental Preservation and Restoration	
ORGANIZATION	FOCUS OF INVOLVEMENT
<b>Alabama Wildlife Center</b> Pelham, Alabama USA <a href="http://www.awrc.org">www.awrc.org</a>	Its mission is to rehabilitate injured and orphaned wild birds and return them to the wild. 
<b>Beach-Clean-up South Carolina Department of Parks, Recreation &amp; Tourism</b> Columbia, South Carolina USA <a href="http://www.discoversouthcarolina.com">http://www.discoversouthcarolina.com</a>	Honda associates and SC DNR utilized Honda (Patent Pending) Rake / Sand Screen Equipment to support beach clean-up efforts for Myrtle Beach State Park.   
<b>Cycle Conservation Club of Michigan</b> Coldwater, Michigan USA <a href="http://www.cycleconservationclub.org">www.cycleconservationclub.org</a>	The Cycle Conservation Club of Michigan is a non-profit organization committed to the conservation of our wild lands while promoting the sport of off-road motorcycling. 
<b>Gladys Porter Zoo</b> Brownsville, Texas USA <a href="http://www.gpz.org/ridley.htm">www.gpz.org/ridley.htm</a>	Honda provides products for use by researchers protecting the endangered Kemp's ridley sea turtle. 
<b>Heal the Bay</b> Santa Monica, California USA <a href="http://www.healthebay.org">www.healthebay.org</a>	Honda associate volunteers participate in the annual California Coastal Cleanup Day, removing trash from a local beach.  
<b>Keep Florence Beautiful/ Adopt A Highway</b> Florence, South Carolina USA <a href="http://www.cityofflorence.com">www.cityofflorence.com</a>	Associates volunteer to clean-up 2.4 miles of road 3 times a year near the Honda facility. We also provided a cash contribution and provide volunteers annually to support the City of Florence on selected roads for the "Great American Clean up" campaign.  
<b>Living Lands &amp; Waters</b> East Moline, Illinois USA <a href="http://www.livinglandsandwaters.org">www.livinglandsandwaters.org</a>	This non-profit is dedicated to the protection, preservation, and restoration of the natural environment of the nation's major rivers and their watersheds, and expands awareness of environmental issues and responsibilities encompassing river systems. 
<b>Mecklenburg County Parks and Recreation</b> Charlotte, North Carolina USA <a href="http://charmeck.org/">http://charmeck.org/</a>	Honda Associates volunteered in clean-up efforts to support the local community park. 













 FINANCIAL SUPPORT

 PRODUCT DONATION

 ASSOCIATE VOLUNTEER

 IN-KIND DONATION

## Environmental Community Activities

Environmental Preservation and Restoration	
ORGANIZATION	FOCUS OF INVOLVEMENT
<b>Miami County Parks</b> Troy, Ohio USA www.miamicountyparks.com	Volunteers planted trees at the Hobart Urban Nature preserve.  
<b>Mote Marine Laboratory</b> Sarasota, Florida USA www.mote.org	Mote has been a leader in marine research since its founding in 1955. Today, it incorporates education and outreach for people of all ages from its seven centers for marine research. 
<b>National Off-Highway Vehicle Conservation Council</b> Great Falls, Montana USA www.nohvcc.org	This organization is dedicated to promoting responsible off-highway vehicle recreation management and resource protection. It works in partnership with private and public land managers and recreation planners, providing educational, safety, ethics, environmental, and character-building programs for all OHV users. 
<b>The Nature Conservancy – Alabama Chapter</b> Birmingham, Alabama USA www.nature.org/alabama	The organization's mission is to preserve plants, animals and natural communities that represent the diversity of life on earth. Honda has supported the Chapter's coastal restoration on the Mobile Bay, stewardship, and volunteer programs.  
<b>The Nature Conservancy – Ohio Chapter</b> Dublin, Ohio USA www.nature.org/ohio	The mission of the Nature Conservancy is to preserve the plants, animals, and natural communities that represent the diversity of life on earth by protecting the lands and waters they need to survive. Honda has supported the Ohio Chapter's establishment of the Big Darby Creek Headwaters Nature Preserve, stewardship and volunteer programs.  
<b>Ohio Department of Transportation</b> Columbus, Ohio USA www.dot.state.oh.us	Honda associates in Raymond participate in the state's Adopt-a-Highway program, cleaning a section of highway near the Honda facility. 
<b>Padre Island Peregrine Falcon Survey</b> Bozeman, Montana USA www.earthspan.org	Honda has donated products to assist scientists studying Peregrine Falcons in their natural habitat. 
<b>Protecting Our Waterways</b> Piqua, Ohio USA	30 volunteers participated in the "Clean Sweep of the Miami River" event. 
<b>Restore Coastal Alabama</b> Mobile Bay, Alabama USA www.nature.org	Honda and 40 associate volunteers joined forces with The Nature Conservancy to construct oyster shell reefs in Mobile Bay to protect the shoreline. Partners included the Alabama Coastal Foundation, Mobile Baykeeper, and the Ocean Foundation.  

 FINANCIAL SUPPORT

 PRODUCT DONATION





 ASSOCIATE VOLUNTEER

 IN-KIND DONATION

## Environmental Community Activities

75

2012 NORTH AMERICAN  
ENVIRONMENTAL REPORT

Environmental Preservation and Restoration	
ORGANIZATION	FOCUS OF INVOLVEMENT
<p><b>San Bernardino National Forest Service Association</b> Big Bear, California USA <a href="http://www.fs.fed.us/r5/business-plans/san-bernardino/financials/success-sbnfa.html">www.fs.fed.us/r5/business-plans/san-bernardino/financials/success-sbnfa.html</a></p>	<p>Since 1993, this group has worked to complement the mission of the U.S. Forest Service. It develops new resources and partnerships that create opportunities, particularly through the efforts of volunteers, for conservation, education, and recreation that add value to the forest's role as public land.</p> <p></p>
<p><b>Save Our Beach</b> Seal Beach, California USA <a href="http://www.saveourbeach.org">www.saveourbeach.org</a></p>	<p>Honda provided a cash contribution and associate volunteers to support beach clean-up efforts.</p> <p> </p>
<p><b>Specialty Vehicle Industry Association</b> Irvine, California USA <a href="http://www.svia.org">www.svia.org</a></p>	<p>Promotes the safe and responsible use of all-terrain vehicles through rider training programs and public awareness campaigns.</p> <p></p>
<p><b>Tigers for Tomorrow</b> Atalla, Alabama USA <a href="http://www.tigersfortomorrow.org">www.tigersfortomorrow.org</a></p>	<p>This exotic animal park and rescue preserve is a "last stop" for exotic animals, which will live the rest of their lives at the park.</p> <p></p>

## Environmental Technology Milestones 1972 – 2000

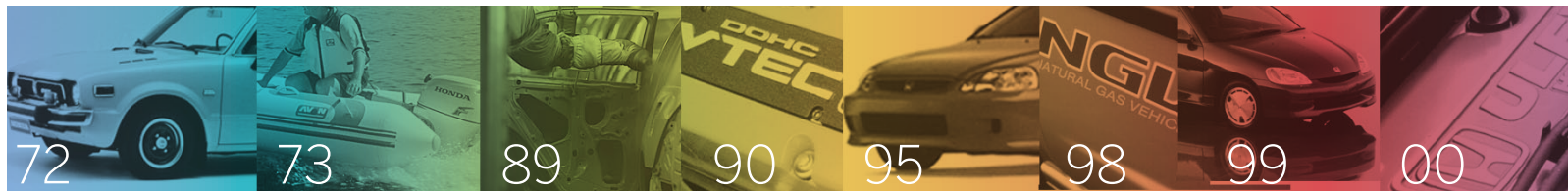

### 1972

Honda announces CVCC (Compound Vortex-Combustion Controlled), the first engine technology to meet U.S. Clean Air Act standards without the need for a catalytic converter.

### 1973

Honda introduces 4-stroke marine engines that are cleaner, more fuel-efficient, and quieter than the 2-stroke outboard motors standard at the time. Honda has manufactured only 4-stroke outboard motors since 1973.

### 1974

First car to meet U.S. Clean Air Act without the use of a catalytic converter solely through engine performance: the 1975 Honda Civic CVCC.

### 1977

The Civic tops the U.S. EPA's list of America's most fuel-efficient cars.

### 1986

The Civic CRX-HF is the first mass-produced 4-cylinder car to break the 50-mpg fuel economy mark.

### 1989

Honda becomes the first automaker in America to use waterborne basecoat paint in mass production.

### 1990

VTEC (Variable Valve Timing and Lift Electronic Control) — Honda's foundational technology for achievements in low emissions, high fuel-efficiency, and high performance, is introduced in the U.S. in the Acura NSX.

### 1995

First gasoline low-emission vehicle (LEV) in the industry is introduced in California: the 1996 Honda Civic.

Fuel economy leadership puts four Honda models on the U.S. EPA's list of the 10 most fuel-efficient cars.

### 1996

The Honda Civic HX Coupe with a continuously variable transmission is the only automatic transmission vehicle to make the U.S. EPA's top-10 list of fuel-efficient cars.

### 1997

First CARB-certified gasoline ultra-low-emission vehicle (ULEV) is introduced: the 1998 Honda Accord.

Honda becomes the first automaker to introduce low-emission vehicle (LEV) technology voluntarily in mass-market vehicles (Honda Civic) throughout the U.S. and Canada.

World's first 360-degree inclinable mini 4-stroke engine for handheld power equipment is introduced by Honda. It is more fuel efficient and virtually smoke free, with ultra-low noise.

First advanced battery-powered electric vehicle is introduced and leased to customers: the 1997 Honda EV Plus.

### 1998

U.S. EPA recognizes the 1998 Honda Civic GX natural gas vehicle as the cleanest internal combustion engine it has ever tested.

Honda introduces ultra-quiet portable inverter generators that achieve substantially higher fuel economy and lower emissions than conventional generators.

Honda becomes the first company to introduce an entire line of high-performance outboard motors that meet U.S. EPA emission standards proposed for the year 2006.

### 1999

First CARB-certified gasoline super-ultra-low-emission vehicle (SULEV) in the industry is introduced: the 2000 Honda Accord.

Honda introduces FCX-V1 and FCX-V2 prototype fuel cell electric vehicles.

First gas-electric hybrid vehicle is introduced in North America: the 2000 Honda Insight.

### 2000

First 50-state ultra-low-emission vehicle (ULEV) is introduced: the 2001 Civic.

First product of any kind receives the Sierra Club Excellence in Environmental Engineering Award: the 2000 Honda Insight.

First vehicle certified as an advanced technology partial zero-emission vehicle (AT-PZEV) by California's Air Resource Board (CARB): the 2001 Civic GX.

## Environmental Technology Milestones 2001 – 2007



### 2001

First production motorcycle certified to meet CARB's 2008 emission standards, the Honda Gold Wing, is sold.

Honda is the first mass-market automaker to offer an entire lineup of cars and light trucks that meet or exceed low-emissions vehicle (LEV) standards.

First solar-powered hydrogen production and fueling station for fuel cell vehicles built and operated by an automaker opens at Honda R&D Americas' Los Angeles Center.

America's first zero waste to landfill auto plant opens in Lincoln, Alabama.

Honda introduces FCX-V3 prototype fuel cell electric vehicle.

Honda introduces first personal watercraft to meet 2006 EPA emissions standards: 2002 AquaTrax F-12 and F-12X.

### 2002

First application of hybrid technology to an existing mass-market car: the 2002 Civic Hybrid.

First fuel cell electric vehicle to receive EPA and CARB certification for commercial use, and the first to meet federal crash safety standards: Honda FCX.

Industry's first lineup of personal watercraft (PWC) powered exclusively by 4-stroke engine technology.

World's first commercial application of a fuel cell electric vehicle: a Honda FCX is leased to the city of Los Angeles.

### 2003

First hybrid vehicle certified AT-PZEV by CARB: 2002 Civic Hybrid.

Honda develops breakthrough fuel cell stack that starts and operates at temperatures below freezing while improving fuel economy, range, and performance.

### 2004

FCX vehicles are leased to the cities of San Francisco and Chula Vista, and the South Coast California Air Quality Management District.

The 2005 FCX, Honda's second-generation fuel cell vehicle, is certified by the EPA as a Tier 2 Bin 1 (ZEV) vehicle and by the CARB as a zero-emission vehicle (ZEV).

World's V-6 hybrid car is introduced: the 2005 Accord.

FCX with cold-weather start capability is leased to state of New York, the first fuel cell customer in the northeastern U.S.

Union of Concerned Scientists gives Honda its "Greenest Automaker" award.

### 2005

World's first fuel cell electric vehicle leased to an individual customer: Honda FCX.

Introduction of Honda Variable Cylinder Management (VCM) technology, the first cylinder deactivation system for an overhead cam (OHC) V6 engine: the 2006 Odyssey minivan.

Introduced iGX computer-controlled general purpose engine, setting a new standard for fuel efficiency and quiet operation.

The 2006 Civic hybrid introduces 4th-generation Honda IMA technology with 50 mpg combined EPA city and highway fuel economy.

### 2006

Honda Soltec, LLC, established for production and sales of Honda-developed CIGS solar panels in Japan.

Retail sales of natural-gas-powered Civic GX expanded from California to New York State.

Honda develops plant-based biofabric for use in automobile interiors.

North American debut of Honda FCX Concept with more compact, powerful, and efficient V Flow stack.

### 2007

Union of Concerned Scientists names Honda the "greenest automaker" for the fourth consecutive time.

World debut of the FCX Clarity with more powerful, efficient, and compact V Flow fuel cell stack.

## Environmental Technology Milestones 2008-2012



### 2008

2008 Civic GX tops the ACEEE "Green Car" list for the fifth straight year.

Honda begins delivery of its next-generation FCX Clarity fuel cell car to customers in Southern California.

### 2009

The 2010 Honda Insight is launched as North America's most affordable mass-produced hybrid automobile.

FCX Clarity named World Green Car of the Year.

### 2010

Honda begins operation of prototype Honda Solar Hydrogen Station at Honda R&D in California.

Honda earns top ranking for the 10th consecutive year in ACEEE = annual rating of America's greenest vehicles.

Honda introduces first affordable sports hybrid: the two-seat CR-Z.

American Honda launches Honda Electric Vehicle Demonstration Program with the first public test drive of a Fit EV.

Honda named America's "greenest automaker" for the fifth consecutive time by the Union of Concerned Scientists.

### 2011

Honda launches 9th-generation Civic lineup including the 41 mpg Civic HF, a new Civic Natural Gas, and new 44 mpg Civic Hybrid, the most fuel-efficient sedan in America.

Ten of 14 Honda plants in North America achieve zero waste to landfill, with total waste to landfills across all 14 plants reduced to just 0.5% of all operating waste.

The 2012 Civic Natural Gas is named "Green Car of the Year" by *Green Car Journal* magazine and a diverse panel of automotive experts.

### 2012

Honda launches retail sales of the 2012 Civic Natural Gas through an expanded sales network, with nearly 200 Honda dealers in 37 states.

American Honda launches Environmental Leadership Award "green dealer" program with U.S. Honda and Acura dealers, including a baseline requirement to reduce energy use by 10%.

Acura introduced the NSX Concept and RLX Concept in North America, both to be powered by versions of Honda's new three-motor hybrid system, dubbed Sport Hybrid Super Handling All-Wheel Drive (SH-AWD).

Leasing of the 2013 Honda Fit EV, with an industry-leading EPA fuel-economy rating of 118 MPGe, begins in California and Oregon.

Launch of 9th-generation Accord with Honda "Earth Dreams Series" powertrains, including new direct-injection 4-cylinder engine and continuously variable transmission (CVT).

Honda announces plans to begin sales of a new hydrogen-powered fuel cell vehicle in the U.S., Japan, and Europe in 2015.

## North American Corporate Profile

Honda develops, manufactures, sells, and services a diverse range of automobile, power equipment, and powersports products in North America. This is Honda's single largest market for the production and sales of Honda and Acura automobiles. As such, Honda's North American region plays a critical role in the company's global effort to reduce its environmental impact, particularly in automobile production and in-use CO<sub>2</sub> emissions.

79

2012 NORTH AMERICAN  
ENVIRONMENTAL REPORT

### Key North American Locations

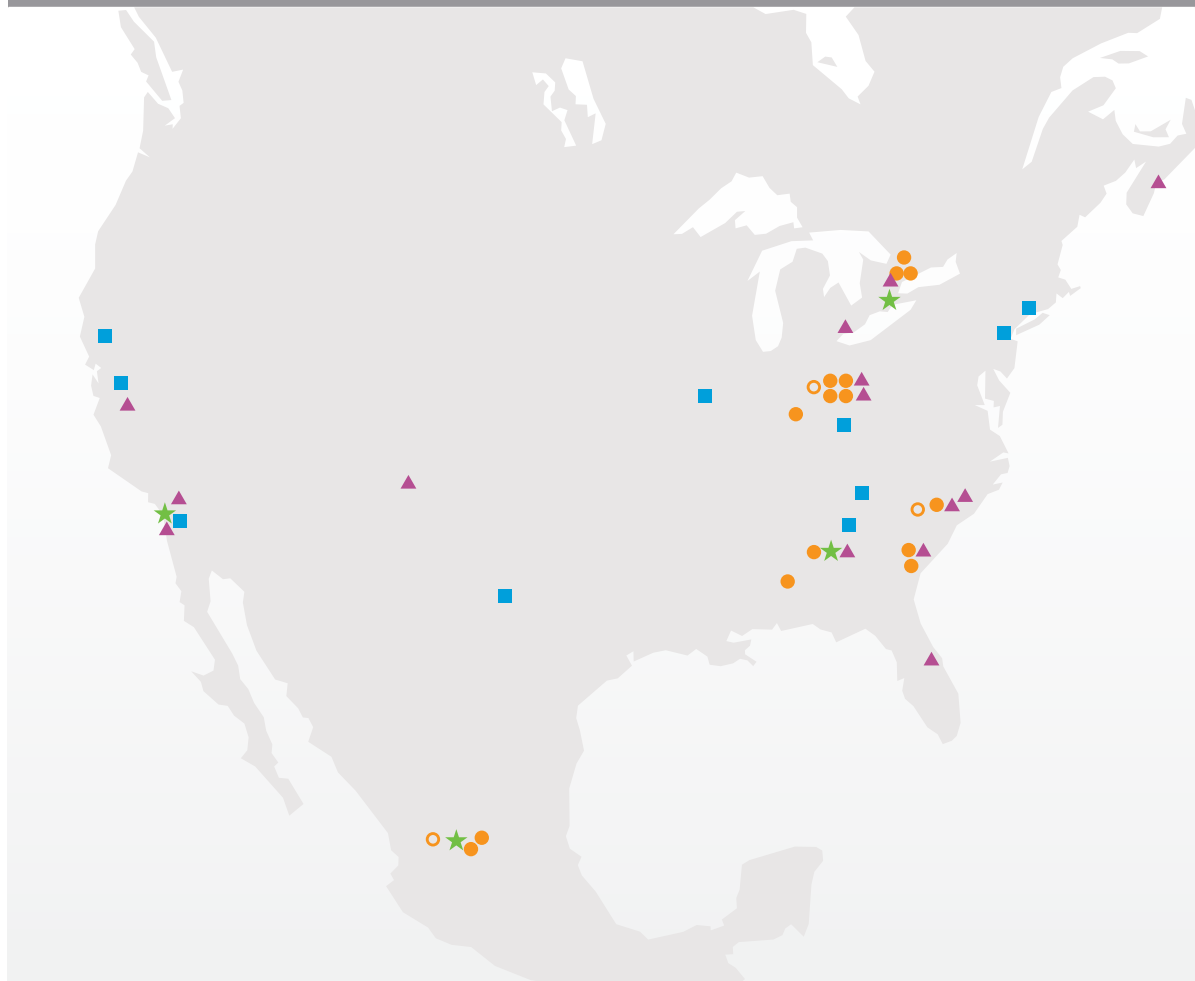

### Capital Investment

\$21 billion

### Employment

Approximately  
24,000 associates



### Parts Purchases

More than \$17.5 billion  
in parts and materials  
purchased from  
more than 600 North  
American original  
equipment suppliers

#### MAP LEGEND

- Major Manufacturing Facilities
- Major Manufacturing Facilities (under development)
- ▲ Research and Development Centers
- Parts Centers
- ★ Sales and Marketing Headquarters

**Additional Information**

	United States	Canada	Mexico
Additional information on Honda and Acura products can be found at:	  <a href="http://www.honda.com">www.honda.com</a>	  <a href="http://www.honda.ca">www.honda.ca</a>	  <a href="http://www.honda.com.mx">www.honda.com.mx</a>
Honda companies covered in this report:	<ul style="list-style-type: none"> <li>American Honda Motor Co., Inc.</li> <li>American Honda Finance Corp.</li> <li>Honda North America, Inc.</li> <li>Honda of America Mfg., Inc.</li> <li>Honda Manufacturing of Alabama, LLC</li> <li>Honda Power Equipment Mfg., Inc.</li> <li>Honda of South Carolina Mfg., Inc.</li> <li>Honda Transmission Mfg. of America, Inc.</li> <li>Honda Manufacturing of Indiana, LLC</li> <li>Honda Engineering North America, Inc.</li> <li>Honda R&amp;D Americas, Inc.</li> <li>Honda Trading America Corp.</li> <li>Honda Precision Parts of Georgia, LLC</li> <li>Honda Aircraft Company, Inc.</li> <li>Honda Aero, Inc.</li> </ul>	<ul style="list-style-type: none"> <li>Honda Canada, Inc.</li> <li>Honda of Canada Mfg., a division of Honda Canada, Inc.</li> <li>Honda R&amp;D Americas, Inc. (Canada)</li> <li>Honda Canada Finance, Inc.</li> <li>Honda Trading Canada, Inc.</li> </ul>	<ul style="list-style-type: none"> <li>Honda de Mexico, S.A. de C.V.</li> </ul>

All trademarks, trade names, service marks, and logos referenced herein belong to their respective companies. All images contained herein are either owned by American Honda Motor Co., Inc., or used under a valid license. It is a violation of federal law to reproduce these images without express written permission from American Honda Motor Co., Inc., or the individual copyright owner of such images. Specifications, features, illustrations, and equipment shown in this report are based upon the latest information available at the time of document release. Although descriptions are believed to be correct, accuracy cannot be guaranteed.

©2012 American Honda Motor Co., Inc.