

Dear Odyssey Owner:

Follow these instructions to properly latch the second row outer seats to the floor. Additionally, there is a video illustrating these instructions. You can view the video by [clicking here](#).

SECOND ROW OUTER SEAT POSITIONS

The two second row outer seats can be installed in two positions, standard and wide:

The second row center seat has only a single seat position.

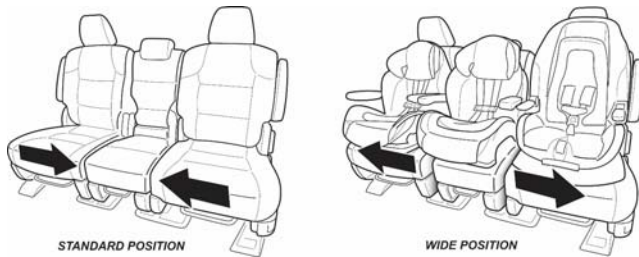

<p>In the <u>standard position</u>, the seats are located inward for:</p> <ul style="list-style-type: none"> • Easier access to the third row. • Maximizing second row outer seat passenger headroom. 	<p>In the <u>wide position</u>, the seats are located outward for:</p> <ul style="list-style-type: none"> • Installation of three car seats in the second row. • Additional hip and shoulder room for passengers in the second row seats.
---	---

LATCHING THE SECOND ROW OUTER SEATS

Follow these steps when installing or repositioning the second row outer seats, and check that the second row seats are secure to help assure passenger safety. **Follow the steps below every time the rear seat latches have been released from the floor.**

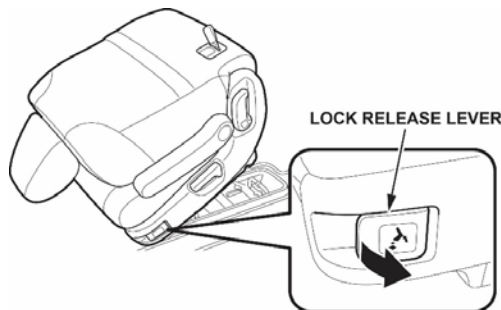

1. Insert the front seat hooks into the front floor strikers.

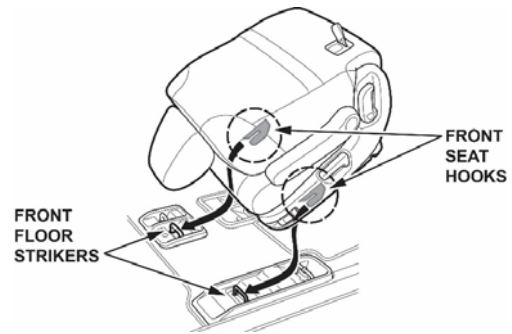

2. Slide the seat into either the standard or wide position.
 - Pull the seat out to the wide position, or push the seat into the standard position until it stops (identified in green).
 - **Do not position the seat hooks in the middle of the striker.** The seat will not lock into position (identified in red).

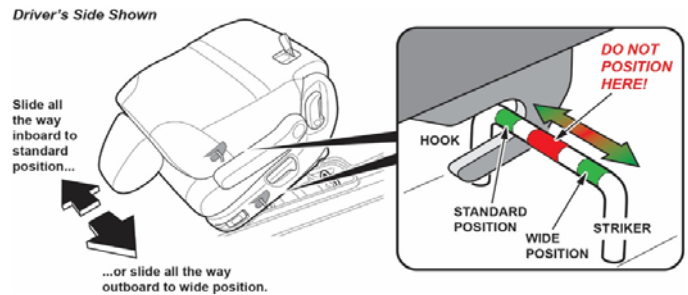

3. Lower the rear of the seat. There is both a rib on the floor and a collar on the rear metal striker. Check that the rear latch and damper are inside or outside of the rib and collar (identified by the green highlight in the illustration):
 - The rib and collar separate the standard and wide seat positions.
 - Do not attempt to latch the seat in the middle (identified in red); the damper and rear latch will rest on the rib and collar and will not lock.

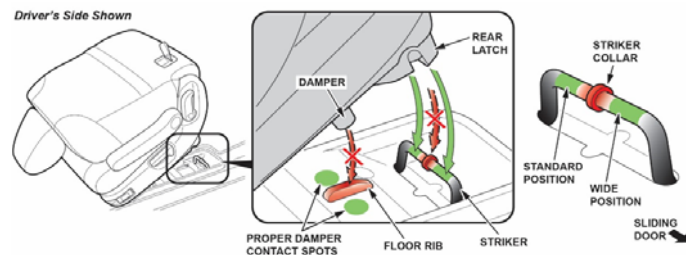

- Press down on the rear part of the seat to set both rear latches. The latches click as they engage the floor strikers.

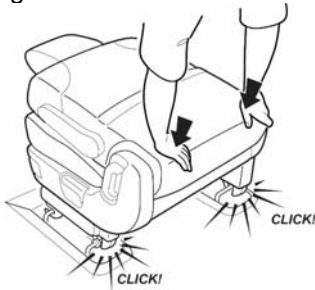

- Raise the seat-back to an upright position, then rock the seat back and forth, trying to tilt it forward, and make sure both the inner and outer latches are locked in position.

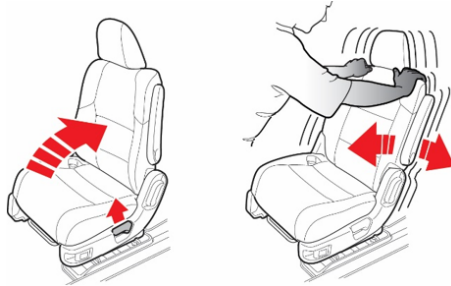

Third Row Seat Access

The two outer second row seats are equipped with a third row access feature that is activated by pulling the third row access lever or strap.

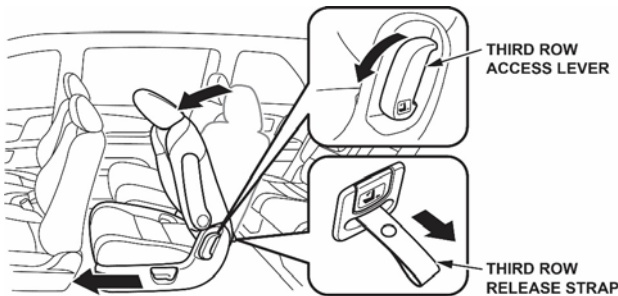

When a child seat is installed in the outer second row seats (typically using the LATCH anchors), the child seat prevents the seat-back from folding forward, which limits access to the third row. Some owners use the seat lock release lever to tip the entire seat forward with the child car seat installed to gain access to the third row.



Honda does not recommend using this method to access the third row seats. When the second row outer seat is tipped forward, the seat may slide into the area between the standard and wide positions that prevents the seats from latching. Therefore, using this method of access increases the risk of having an unsecured second row outer seat.

Driver's Side Shown

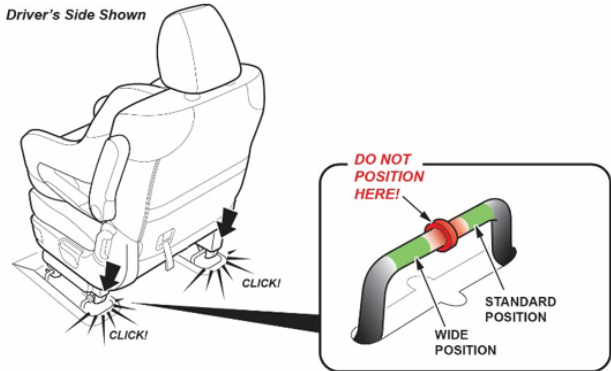

If despite the risks you choose to tip the entire second row seat forward to access the third row, make sure the seat is in the standard or wide position when lowering and latching the seat.

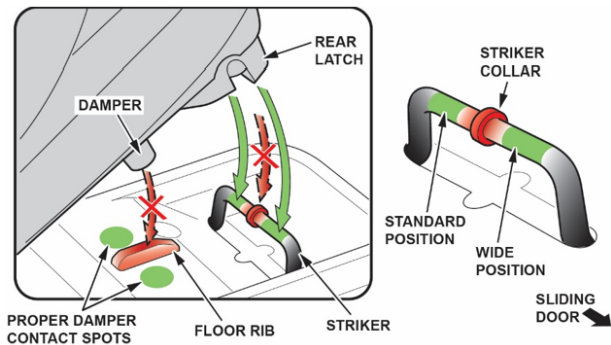

Check that the seat is latched by rocking the seat back and forth, trying to tilt it forward, and make sure both the inner and outer latches are locked and the front seat hooks are under the front latches.

